

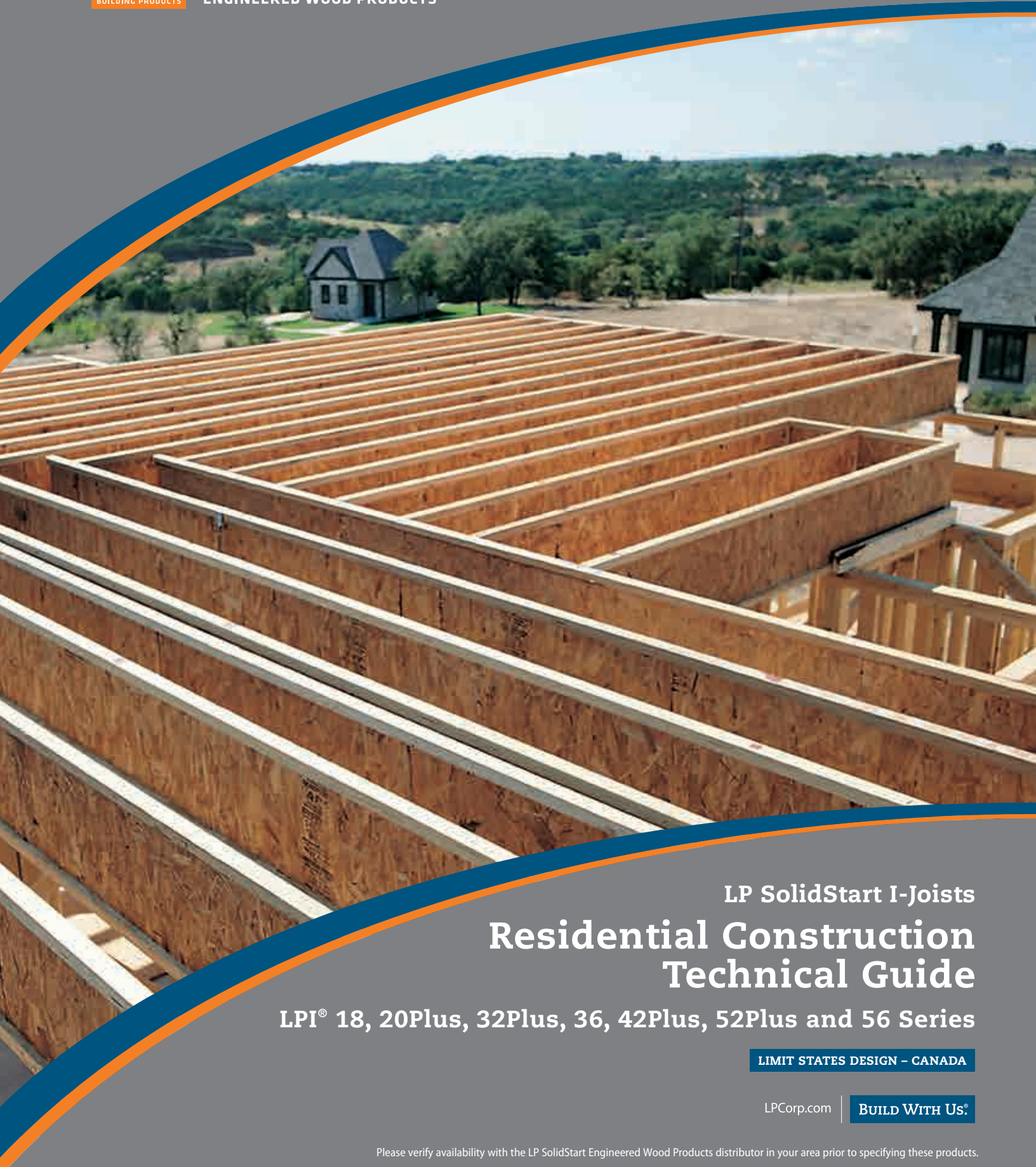

SOLIDSTART[®]
ENGINEERED WOOD PRODUCTS



LP SolidStart I-Joists Residential Construction Technical Guide

LPI[®] 18, 20Plus, 32Plus, 36, 42Plus, 52Plus and 56 Series

LIMIT STATES DESIGN - CANADA

LPCorp.com

BUILD WITH US[®]

Please verify availability with the LP SolidStart Engineered Wood Products distributor in your area prior to specifying these products.

LP® SolidStart® I-Joists are straighter and more uniform in strength, stiffness and size than traditional lumber, providing a strong, sturdy floor. We offer longer lengths so that ceilings and floors can be designed with fewer pieces, saving time on installation. Other advantages over lumber include lower moisture content, which makes our I-Joists less likely to split, shrink, twist, warp or bow. This means reduced callbacks due to fewer pops and squeaks.

STRENGTH IN NUMBERS

LP's full range of SolidStart products are designed and manufactured to install easily and work together to provide a strong, sound structure.

For I-joists, we combine laminated veneer lumber (LVL) or finger-jointed sawn lumber flanges with a web of oriented strand board (OSB) to produce an I-shaped structural member. The webs allow plumbing and wiring to pass through without extra framing, while the flanges resist bending – ideal for long spans in floors, ceilings and roofs.

LP SolidStart I-JOISTS ARE A BUILDING MATERIAL WITH BUILT-IN ENVIRONMENTAL BENEFITS

- Made of engineered wood substrate, a renewable resource with a reduced environmental impact
- Raw material procurement targets small, fast growing trees
- In LP's manufacturing process, no part of the log goes to waste
- Only low-emitting, safe resins are used as a binder
- Available in longer lengths, reducing the number of pieces needed; this results in more efficient utilization of resources
- Can help you qualify for certification points in a number of leading green building programs



COMPLIANT WITH MAJOR BUILDING CODES

LP SolidStart I-Joists have been evaluated by CCMC for compliance with the National Building Code of Canada. Contact your local LP SolidStart Engineered Wood Products distributor or visit www.lpcorp.com for the most current code reports.

LIFETIME LIMITED WARRANTY

LP SolidStart Engineered Wood Products are backed by a lifetime limited warranty. Visit LPCorp.com or call 1.888.820.0325 for a copy of the warranty.



- Product Specifications & Design Values 4
- Web Stiffeners, Rim & Blocking, Nailing 5
- Floor Span Tables 6-9
- Uniform Floor Load (PLF) Tables 10-11
- Uniform Roof Load (PLF) Tables 12-13
- Roof Span Tables: Low Pitch (6:12 or less) 14-15
- Roof Span Tables: High Pitch (6:12 to 12:12) 16-17
- Cantilevers 18-19
- Web Hole Specifications: Circular Holes 20
- Web Hole Specifications: Rectangular Holes 21
- Floor Details 22-23
- Roof Details 24
- Framing Connectors 25
- LP® SolidStart® Rim Board 26
- Warnings 27
- Handling and Storage Guidelines 28

Product Specifications & Design Values

LIMIT STATES DESIGN VALUES						
Series	Depth	Weight (plf)	Factored Moment (lb-ft)	EI (x 10 ⁶) (lb-in ²)	K (x 10 ⁶) (lb-ft/in)	Factored Shear (lbs)
LPI 18	9-1/2"	2.6	3760	142	0.355	1785
	11-7/8"	2.9	4450	248	0.435	2105
	14"	3.1	6185	371	0.508	2385
LPI 20Plus	9-1/2"	2.6	4670	185	0.358	1990
	11-7/8"	2.9	6250	318	0.438	2345
	14"	3.1	7320	474	0.512	2650
	16"	3.3	8400	652	0.582	2950
LPI 32Plus	9-1/2"	2.6	5570	221	0.358	1990
	11-7/8"	2.9	7210	375	0.438	2345
	14"	3.1	8680	549	0.512	2650
	16"	3.3	10065	743	0.582	2950
LPI 36	11-7/8"	3.1	10715	429	0.468	2550
	14"	3.4	12900	622	0.550	2890
	16"	3.6	14960	836	0.625	3190
LPI 42Plus	9-1/2"	3.4	8940	321	0.412	2115
	11-7/8"	3.5	11585	547	0.515	2565
	14"	3.8	13950	802	0.607	2960
	16"	4.0	16180	1092	0.693	3340
LPI 52Plus	11-7/8"	4.5	14085	600	0.633	3245
	14"	4.8	16960	874	0.747	3680
	16"	5.0	19670	1183	0.853	4080
LPI 56	11-7/8"	4.5	16920	668	0.549	3245
	14"	4.8	20370	968	0.641	3680
	16"	5.0	23625	1301	0.729	4080

NOTES:

- LP® SolidStart® I-joists shall be designed for dry-use conditions only. Dry-use applies to products installed in dry, covered and well ventilated interior conditions in which the equivalent average moisture content in lumber will not exceed 15% nor a maximum of 19%.
- Moment and Shear are the factored resistances for standard load duration and shall be adjusted according to code.
- Moment resistance shall not be increased for repetitive member use.
- Deflection calculations shall include both bending and shear deformations. Deflection for a simple span, uniform load:

$$\Delta = \frac{22.5wL^4}{EI} + \frac{wL^2}{K}$$

Where: Δ = deflection (in) EI = bending stiffness (from table)

w = uniform load (plf) K = shear stiffness (from table)

L = design span (ft)

Equations for other conditions can be found in engineering references.

FACTORED REACTION AND BEARING RESISTANCE

Series	Depth	End Reaction Resistance ¹ (lbs)				Interior Reaction Resistance ¹ (lbs)				Factored Reaction and Bearing Resistance Flange Bearing Resistance, ϕF _{cp} (lb/in)
		Minimum Bearing (1-1/2")		Maximum Bearing (4")		Minimum Bearing (3-1/2")		Maximum Bearing (5-1/2")		
		W/out Stiffeners	With Stiffeners	W/out Stiffeners	With Stiffeners	W/out Stiffeners	With Stiffeners	W/out Stiffeners	With Stiffeners	
LPI 18	9-1/2"	1375	1620	1570	1785	3115	3370	3480	3740	1380
	11-7/8"	1375	1805	1640	2105	3305	3585	3685	4015	
	14"	1375	1980	1705	2385	3480	3780	3865	4260	
LPI 20Plus	9-1/2"	1530	1800	1750	1990	3465	3750	3865	4160	1380
	11-7/8"	1530	2010	1830	2345	3680	3985	4095	4465	
	14"	1530	2200	1895	2650	3875	4205	4300	4745	
	16"	1530	2385	1955	2950	4055	4410	4500	5010	
LPI 32Plus	9-1/2"	1530	1800	1750	1990	3465	3750	3865	4160	1695
	11-7/8"	1530	2010	1830	2345	3680	3985	4095	4465	
	14"	1530	2200	1895	2650	3875	4205	4300	4745	
	16"	1530	2385	1955	2950	4055	4410	4500	5010	
LPI 36	11-7/8"	1620	2370	2030	2550	3940	4900	4475	5475	1720
	14"	1620	2390	2090	2890	3940	5060	4475	5625	
	16"	1620	2405	2145	3190	3940	5215	4475	5770	
LPI 42Plus	9-1/2"	1870	2115	2060	2115	4575	4885	4640	5045	2450
	11-7/8"	1965	2385	2520	2565	4775	5270	4925	5550	
	14"	2050	2620	2520	2960	4955	5625	5175	6005	
	16"	2130	2840	2520	3340	5120	5960	5420	6440	
LPI 52Plus	11-7/8"	2160	2875	2670	3245	5400	6315	5740	6645	2450
	14"	2185	3110	2910	3680	5420	6725	5910	7165	
	16"	2210	3330	3135	4080	5445	7110	6075	7665	
LPI 56	11-7/8"	1805	2620	2390	3245	4940	6090	5795	6410	2720
	14"	1805	2770	2425	3680	4940	6400	5795	6785	
	16"	1805	2910	2455	4080	4940	6700	5795	7140	

NOTES

- End and Interior Reaction Resistance shall be limited by the Flange Bearing Resistance or the bearing resistance of the support material, whichever is less.
- The Flange Bearing Resistance per inch of bearing length, is based on the compression perpendicular-to-grain of the I-joist flange, accounting for eased edges.
- To account for edge easing when determining the bearing capacity of the support material, subtract 0.25" from the flange width for the LPI 18, LPI 20Plus, LPI 32Plus, LPI 42Plus & LPI 52Plus, and subtract 0.10" from the flange width for the LPI 36 & LPI 56.
- Reaction Resistance, Flange Bearing Resistance and the bearing resistance of any wood support are for standard load duration and shall be reduced according to code for longer loading duration.
- Reaction Resistance and Flange Bearing Resistance may be increased over that tabulated for the minimum bearing length. Linear interpolation of the Reaction Resistance between the minimum and maximum bearing length is permitted. Bearing lengths longer than the maximum do not further increase Reaction Resistance. Flange Bearing Resistance and that of a wood support will increase with additional bearing length.
- The Interior Reaction Resistance may be calculated to a minimum bearing length of 3 inches, based on the 3-1/2" and 5-1/2" values.
- See page 5 for information on web stiffener sizes and nailing.

EXAMPLE:

Determine the stiffened end reaction capacity for a 14" LPI 32Plus with 2" of bearing for a non-snow roof load and supported on an SPF wall plate (768 psi).

- Determine End Reaction (ER) w/Stiffeners:
ER = 2200 + (2650 - 2200) * (2" - 1.5") / (4" - 1.5") = 2290 lbs
- Determine Flange Bearing Resistance (FBR):
FBR = 1695 lb/in * 2" = 3390 lbs
- Determine wall Plate Bearing Resistance (PBR):
PBR = 0.8 * 768 psi * (2.5" - 0.25") * 2" = 2764 lbs
- Final End Reaction Resistance w/Stiffeners = 2290 lbs

PROFILE DETAILS

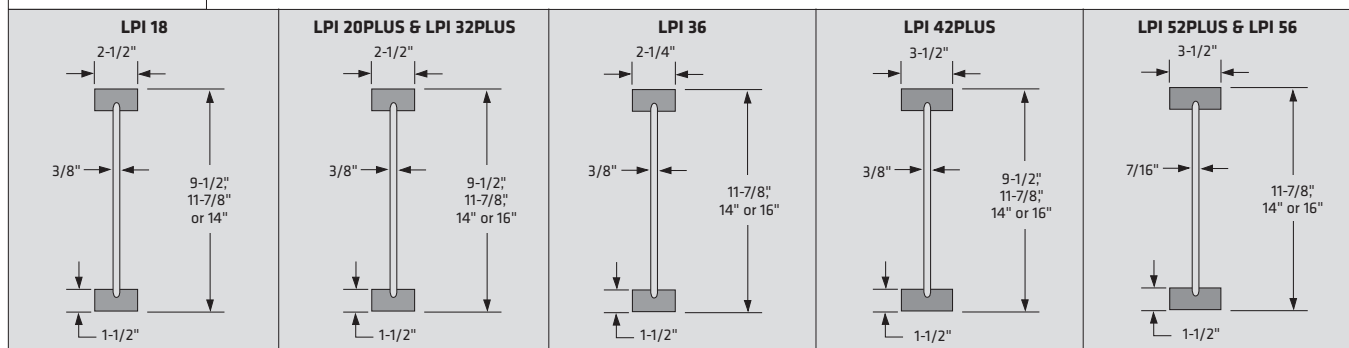

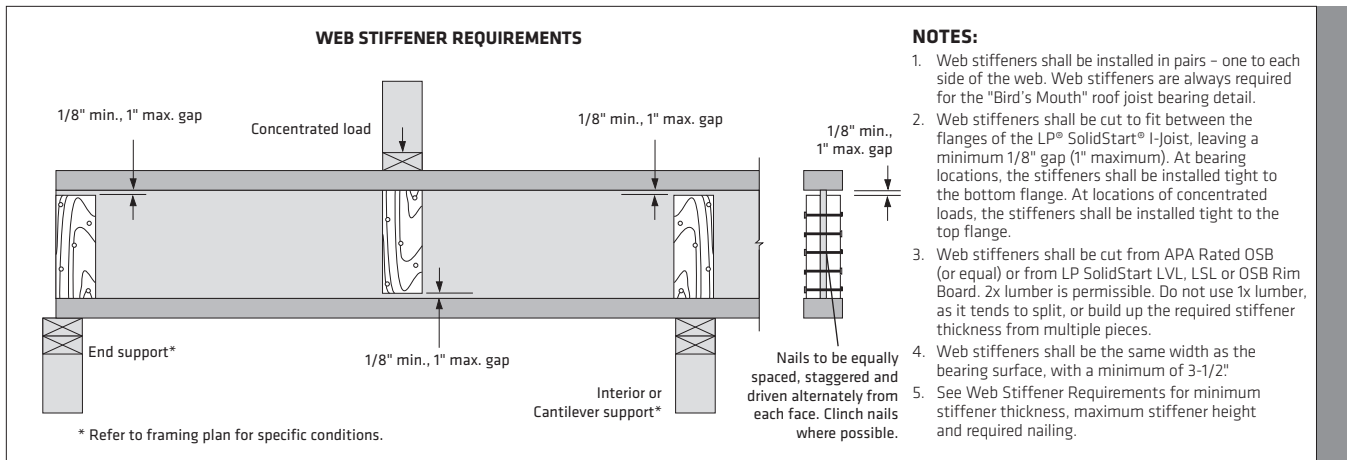

WEB STIFFENER REQUIREMENTS					
Series	Depth	Minimum Thickness	Maximum Height	Nail Size*	Nail Qty
LPI 18 LPI 20Plus LPI 32Plus	9-1/2"	23/32"	6-3/8"	8d (2-1/2")	3
	11-7/8"	23/32"	8-3/4"	8d (2-1/2")	3
	14"	23/32"	10-7/8"	8d (2-1/2")	3
	16"	23/32"	12-7/8"	8d (2-1/2")	3
LPI 36	11-7/8"	23/32"	8-3/4"	8d (2-1/2")	4
	14"	23/32"	10-7/8"	8d (2-1/2")	5
	16"	23/32"	12-7/8"	8d (2-1/2")	6
LPI 42Plus LPI 52Plus	9-1/2"	1-1/2"	6-3/8"	10d (3")	3
	11-7/8"	1-1/2"	8-3/4"	10d (3")	3
	14"	1-1/2"	10-7/8"	10d (3")	3
	16"	1-1/2"	12-7/8"	10d (3")	3
LPI 56	11-7/8"	1-1/2"	8-3/4"	10d (3")	4
	14"	1-1/2"	10-7/8"	10d (3")	5
	16"	1-1/2"	12-7/8"	10d (3")	6

* Nail Size is for common wire nails.

RIM & BLOCKING CAPACITY		
Series	Depth	Factored Vertical Resistance
		(plf)
LPI 18 LPI 20Plus	9-1/2"	2670
	11-7/8"	2470
	14"	2250
LPI 20Plus	16"	2110
LPI 32Plus LPI 42Plus	9-1/2"	3090
	11-7/8"	3090
	14"	2250
	16"	2110
LPI 36	11-7/8"	2530
	14"	2530
	16"	2530
LPI 52Plus LPI 56	11-7/8"	3380
	14"	3100
	16"	2670

NOTES:

1. The Factored Vertical Resistance is the capacity in pounds per lineal foot of length (plf) and shall not be adjusted for load duration.
2. Concentrated vertical loads require the addition of squash blocks. Do not use LPI rim or blocking to support concentrated vertical loads.
3. Lateral load resistance for all series above is 260 plf but may be limited by the connection details used. Do not exceed the Flange Face Nailing requirements above.

FLANGE FACE NAILING			
Series	Common Wire Nail Size	Minimum Nail Distance	
		oc Spacing	End
LPI 18 LPI 20Plus LPI 32Plus LPI 42Plus LPI 52Plus	2-1/2"	2"	1"
	3"	3"	1-1/2"
	3-1/4"	3"	1-1/2"
	3-1/2"	4"	1-1/2"
LPI 36 LPI 56	2-1/2"	3"	1-1/2"
	3"	3"	1-1/2"
	3-1/4"	3"	1-1/2"
	3-1/2"	5"	1-1/2"

NOTES:

1. Use only 2-1/2" or 3" nails when securing an LPI floor or roof joist to its supports.
2. Power-driven nails shall have a yield strength equivalent to common wire nails of the same shank diameter.

Floor Span Tables: 19/32" OSB Sheathing

SPECIFIED FLOOR LOADS: 40 PSF LIVE LOAD, 15 PSF DEAD LOAD

TO USE:

1. Select the appropriate table based on the floor system construction.
2. Select the Simple Span or Continuous Span section of the table, as required.
3. Find a span that meets or exceeds the required clear span.
4. Read the corresponding joist series, depth and spacing.

CAUTION: For floor systems that require both simple span and continuous span joists, it is a good idea to check both before selecting a joist. Some conditions are controlled by continuous span rather than simple span.

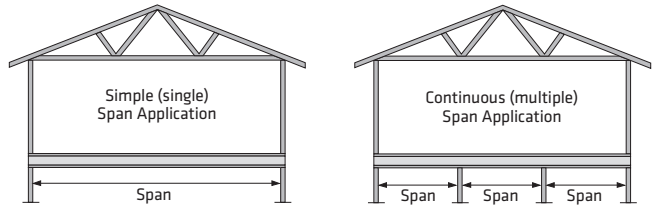

19/32" OSB SHEATHING NAILED ONLY

Series	Depth	No Direct Attached Ceiling						Direct Attached 1/2" Gypsum Ceiling					
		Maximum Simple Spans			Maximum Continuous Spans			Maximum Simple Spans			Maximum Continuous Spans		
		12" oc	16" oc	19.2" oc	12" oc	16" oc	19.2" oc	12" oc	16" oc	19.2" oc	12" oc	16" oc	19.2" oc
LPI 18	9'-1/2"	13'-8"	12'-9"	12'-3"	14'-10"	13'-10"	13'-3"	14'-1"	13'-2"	12'-7"	15'-3"	14'-3"	13'-8"
	11'-7/8"	15'-5"	14'-5"	13'-10"	16'-9"	15'-8"	15'-0"	15'-11"	14'-11"	14'-3"	17'-4"	16'-2"	15'-6"
	14"	16'-11"	15'-9"	15'-2"	18'-5"	17'-1"	16'-5"	17'-5"	16'-3"	15'-8"	19'-2"	17'-8"	17'-0"
LPI 20Plus	9'-1/2"	14'-5"	13'-6"	12'-11"	15'-8"	14'-7"	14'-0"	14'-10"	13'-10"	13'-3"	16'-1"	15'-0"	14'-5"
	11'-7/8"	16'-3"	15'-2"	14'-7"	17'-8"	16'-6"	15'-10"	16'-9"	15'-7"	15'-0"	18'-2"	17'-0"	16'-4"
	14"	17'-9"	16'-7"	15'-11"	19'-8"	18'-0"	17'-3"	18'-4"	17'-1"	16'-5"	20'-5"	18'-8"	17'-10"
LPI 32Plus	9'-1/2"	15'-0"	14'-0"	13'-5"	16'-3"	15'-2"	14'-7"	15'-4"	14'-4"	13'-9"	16'-8"	15'-7"	14'-11"
	11'-7/8"	16'-10"	15'-8"	15'-1"	18'-4"	17'-0"	16'-4"	17'-3"	16'-1"	15'-6"	19'-0"	17'-6"	16'-10"
	14"	18'-5"	17'-1"	16'-5"	20'-5"	18'-8"	17'-10"	19'-1"	17'-7"	16'-10"	21'-2"	19'-5"	18'-5"
LPI 36	11'-7/8"	17'-4"	16'-2"	15'-6"	19'-0"	17'-7"	16'-10"	17'-9"	16'-7"	15'-11"	19'-8"	18'-0"	17'-4"
	14"	19'-1"	17'-7"	16'-10"	21'-2"	19'-4"	18'-5"	19'-9"	18'-0"	17'-4"	21'-11"	20'-1"	19'-1"
	16"	20'-9"	19'-0"	18'-0"	23'-0"	21'-1"	20'-0"	21'-6"	19'-8"	18'-8"	23'-10"	21'-10"	20'-9"
LPI 42Plus	9'-1/2"	16'-3"	15'-2"	14'-6"	17'-7"	16'-5"	15'-9"	16'-7"	15'-6"	14'-10"	18'-0"	16'-10"	16'-2"
	11'-7/8"	18'-4"	17'-1"	16'-4"	20'-5"	18'-8"	17'-9"	18'-11"	17'-5"	16'-9"	21'-0"	19'-3"	18'-3"
	14"	20'-6"	18'-9"	17'-10"	22'-9"	20'-10"	19'-9"	21'-1"	19'-4"	18'-4"	23'-5"	21'-6"	20'-4"
LPI 52Plus	11'-7/8"	19'-0"	17'-6"	16'-10"	21'-0"	19'-3"	18'-4"	19'-6"	17'-11"	17'-2"	21'-8"	19'-10"	18'-10"
	14"	21'-2"	19'-4"	18'-4"	23'-5"	21'-5"	20'-5"	21'-9"	19'-11"	18'-11"	24'-1"	22'-1"	21'-0"
	16"	23'-1"	21'-1"	20'-0"	25'-7"	23'-5"	22'-3"	23'-9"	21'-9"	20'-7"	26'-4"	24'-1"	22'-11"
LPI 56	11'-7/8"	19'-5"	17'-10"	17'-1"	21'-7"	19'-8"	18'-9"	19'-11"	18'-3"	17'-5"	22'-2"	20'-3"	19'-3"
	14"	21'-7"	19'-8"	18'-8"	23'-11"	21'-11"	20'-9"	22'-2"	20'-3"	19'-3"	24'-8"	22'-7"	21'-5"
	16"	23'-6"	21'-5"	20'-4"	26'-1"	23'-10"	22'-7"	24'-2"	22'-1"	20'-11"	26'-10"	24'-7"	23'-4"

19/32" OSB SHEATHING GLUED & NAILED

Series	Depth	No Direct Attached Ceiling						Direct Attached 1/2" Gypsum Ceiling					
		Maximum Simple Spans			Maximum Continuous Spans			Maximum Simple Spans			Maximum Continuous Spans		
		12" oc	16" oc	19.2" oc	12" oc	16" oc	19.2" oc	12" oc	16" oc	19.2" oc	12" oc	16" oc	19.2" oc
LPI 18	9'-1/2"	14'-11"	14'-1"	13'-8"	16'-2"	15'-3"	14'-10"	15'-5"	14'-7"	14'-1"	16'-8"	15'-10"	15'-2"
	11'-7/8"	16'-9"	15'-10"	15'-4"	18'-2"	17'-2"	16'-7"	17'-4"	16'-5"	15'-10"	19'-0"	17'-9"	16'-7"
	14"	18'-4"	17'-3"	16'-8"	20'-3"	18'-10"	18'-1"	19'-1"	17'-10"	17'-3"	21'-2"	19'-9"	18'-11"
LPI 20Plus	9'-1/2"	15'-7"	14'-8"	14'-3"	16'-10"	15'-11"	15'-5"	16'-0"	15'-1"	14'-8"	17'-4"	16'-5"	15'-10"
	11'-7/8"	17'-5"	16'-5"	15'-11"	19'-1"	17'-10"	17'-3"	17'-11"	17'-0"	16'-5"	19'-10"	18'-6"	17'-10"
	14"	19'-3"	17'-11"	17'-4"	21'-3"	19'-9"	18'-11"	20'-0"	18'-7"	17'-10"	22'-2"	20'-7"	19'-9"
LPI 32Plus	9'-1/2"	16'-0"	15'-1"	14'-7"	17'-4"	16'-4"	15'-10"	16'-5"	15'-6"	15'-0"	17'-10"	16'-10"	16'-3"
	11'-7/8"	17'-11"	16'-11"	16'-4"	19'-9"	18'-4"	17'-9"	18'-6"	17'-5"	16'-10"	20'-6"	19'-1"	18'-4"
	14"	19'-10"	18'-5"	17'-9"	22'-0"	20'-5"	19'-6"	20'-7"	19'-1"	18'-4"	22'-10"	21'-2"	20'-4"
LPI 36	11'-7/8"	18'-5"	17'-4"	16'-9"	20'-5"	18'-11"	18'-2"	19'-1"	17'-9"	17'-2"	21'-1"	19'-7"	18'-10"
	14"	20'-5"	18'-11"	18'-2"	22'-7"	21'-0"	20'-1"	21'-2"	19'-7"	18'-9"	23'-5"	21'-9"	20'-10"
	16"	22'-2"	20'-7"	19'-8"	24'-7"	22'-9"	21'-10"	23'-0"	21'-4"	20'-5"	25'-5"	23'-8"	22'-8"
LPI 42Plus	9'-1/2"	17'-1"	16'-1"	15'-7"	18'-8"	17'-5"	16'-10"	17'-6"	16'-6"	15'-11"	19'-3"	17'-11"	17'-3"
	11'-7/8"	19'-6"	18'-0"	17'-5"	21'-7"	20'-0"	19'-2"	20'-1"	18'-7"	17'-10"	22'-3"	20'-8"	19'-9"
	14"	21'-8"	20'-0"	19'-2"	24'-0"	22'-2"	21'-3"	22'-4"	20'-8"	19'-9"	24'-9"	22'-11"	21'-11"
LPI 52Plus	11'-7/8"	20'-0"	18'-7"	17'-10"	22'-2"	20'-6"	19'-8"	20'-7"	19'-1"	18'-3"	22'-10"	21'-2"	20'-3"
	14"	22'-3"	20'-7"	19'-8"	24'-7"	22'-9"	21'-9"	22'-11"	21'-2"	20'-3"	25'-4"	23'-6"	22'-6"
	16"	24'-3"	22'-5"	21'-5"	26'-10"	24'-9"	23'-8"	24'-11"	23'-1"	22'-1"	27'-7"	25'-7"	24'-5"
LPI 56	11'-7/8"	20'-5"	18'-11"	18'-1"	22'-8"	20'-11"	20'-0"	21'-0"	19'-5"	18'-7"	23'-3"	21'-7"	20'-7"
	14"	22'-8"	20'-11"	20'-0"	25'-1"	23'-2"	22'-2"	23'-4"	21'-7"	20'-7"	25'-10"	23'-11"	22'-10"
	16"	24'-7"	22'-9"	21'-9"	27'-3"	25'-2"	24'-1"	25'-4"	23'-5"	22'-4"	28'-1"	26'-0"	24'-10"

DESIGN ASSUMPTIONS:

1. The spans listed are the clear distance between supports. Continuous spans are based on the longest span. The shortest span shall not be less than 50% of the longest span.
2. The spans are based on uniform floor loads only, for standard load duration.
3. These tables reflect the additional stiffness for vibration provided by a 19/32" OSB rated sheathing, or equal, attached as indicated (Nailed Only or Glued & Nailed) to the top flange.
4. Live load deflection is limited to L/360 "bare joist".
5. Total load deflection is limited to L/240 "bare joist".
6. The spans are based on an end bearing length of at least 1-3/4" and an interior bearing length of at least 3-1/2", and are limited to the bearing resistance of an SPF wall plate.

ADDITIONAL NOTES:

1. These spans have been designed to meet the Limit States Design and vibration requirements of the National Building Code of Canada.
2. Web stiffeners are not required for any of the spans in these tables.
3. Web fillers are required for I-joists seated in hangers that do not laterally support the top flange.
4. For conditions not shown, use the Uniform Floor Load (PLF) tables, LP's design software or contact your LP® SolidStart® Engineered Wood Products distributor for assistance.

Floor Span Tables: 23/32" OSB Sheathing

SPECIFIED FLOOR LOADS: 40 PSF LIVE LOAD, 15 PSF DEAD LOAD

TO USE:

1. Select the appropriate table based on the floor system construction.
2. Select the Simple Span or Continuous Span section of the table, as required.
3. Find a span that meets or exceeds the required clear span.
4. Read the corresponding joist series, depth and spacing.

CAUTION: For floor systems that require both simple span and continuous span joists, it is a good idea to check both before selecting a joist. Some conditions are controlled by continuous span rather than simple span.

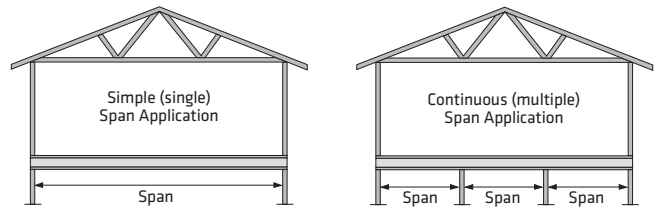

23/32" OSB SHEATHING NAILED ONLY

Series	Depth	No Direct Attached Ceiling								Direct Attached 1/2" Gypsum Ceiling							
		Maximum Simple Spans				Maximum Continuous Spans				Maximum Simple Spans				Maximum Continuous Spans			
		12" oc	16" oc	19.2" oc	24" oc	12" oc	16" oc	19.2" oc	24" oc	12" oc	16" oc	19.2" oc	24" oc	12" oc	16" oc	19.2" oc	24" oc
LPI 18	9-1/2"	14'-4"	13'-4"	12'-9"	12'-2"	15'-6"	14'-6"	13'-10"	13'-2"	14'-8"	13'-9"	13'-2"	12'-6"	15'-11"	14'-11"	14'-3"	13'-7"
	11-7/8"	16'-2"	15'-1"	14'-5"	13'-9"	17'-1"	16'-4"	15'-8"	14'-9"	16'-8"	15'-6"	14'-10"	14'-2"	18'-1"	16'-10"	16'-2"	14'-9"
	14"	17'-9"	16'-6"	15'-10"	15'-0"	19'-6"	17'-11"	17'-2"	16'-4"	18'-3"	17'-0"	16'-3"	15'-6"	20'-3"	18'-7"	17'-8"	16'-10"
LPI 20Plus	9-1/2"	15'-2"	14'-1"	13'-6"	12'-10"	16'-5"	15'-3"	14'-8"	13'-11"	15'-6"	14'-5"	13'-10"	13'-2"	16'-10"	15'-8"	15'-0"	14'-4"
	11-7/8"	17'-1"	15'-11"	15'-2"	14'-6"	18'-7"	17'-3"	16'-6"	15'-9"	17'-3"	16'-4"	15'-7"	14'-10"	19'-3"	17'-8"	16'-11"	16'-2"
	14"	18'-10"	17'-4"	16'-7"	15'-10"	20'-10"	19'-1"	18'-0"	17'-2"	19'-5"	17'-10"	17'-1"	16'-3"	21'-6"	19'-9"	18'-8"	17'-8"
LPI 32Plus	9-1/2"	15'-8"	14'-7"	14'-0"	13'-4"	17'-0"	15'-10"	15'-2"	14'-6"	16'-1"	15'-0"	14'-4"	13'-7"	17'-5"	16'-3"	15'-7"	14'-10"
	11-7/8"	17'-8"	16'-5"	15'-9"	15'-0"	19'-5"	17'-10"	17'-1"	16'-3"	18'-1"	16'-10"	16'-1"	15'-4"	20'-0"	18'-4"	17'-6"	16'-8"
	14"	19'-7"	17'-11"	17'-1"	16'-3"	21'-8"	19'-10"	18'-9"	17'-8"	20'-2"	18'-5"	17'-7"	16'-8"	22'-4"	20'-6"	19'-4"	18'-2"
LPI 36	11-7/8"	18'-3"	16'-11"	16'-2"	15'-5"	20'-2"	18'-6"	17'-7"	16'-9"	18'-9"	17'-4"	16'-7"	15'-9"	20'-9"	19'-0"	18'-0"	17'-2"
	14"	20'-3"	18'-6"	17'-7"	16'-9"	22'-6"	20'-6"	19'-5"	18'-3"	20'-10"	19'-1"	18'-0"	17'-2"	23'-1"	21'-2"	20'-0"	18'-10"
	16"	22'-1"	20'-2"	19'-0"	17'-11"	24'-5"	22'-4"	21'-1"	19'-8"	22'-8"	20'-9"	19'-7"	18'-5"	25'-2"	23'-1"	21'-10"	19'-8"
LPI 42Plus	9-1/2"	17'-0"	15'-10"	15'-2"	14'-5"	18'-7"	17'-3"	16'-6"	15'-8"	17'-4"	16'-2"	15'-6"	14'-9"	19'-1"	17'-7"	16'-10"	16'-0"
	11-7/8"	19'-6"	17'-10"	17'-1"	16'-3"	21'-8"	19'-9"	18'-8"	17'-8"	20'-0"	18'-3"	17'-5"	16'-7"	22'-2"	20'-4"	19'-2"	18'-1"
	14"	21'-9"	19'-10"	18'-9"	17'-8"	24'-2"	22'-1"	20'-10"	19'-7"	22'-4"	20'-5"	19'-3"	18'-1"	24'-9"	22'-8"	21'-5"	20'-2"
LPI 52Plus	11-7/8"	20'-2"	18'-5"	17'-7"	16'-9"	22'-4"	20'-5"	19'-4"	18'-2"	20'-7"	18'-10"	17'-11"	17'-0"	22'-10"	20'-11"	19'-10"	18'-7"
	14"	22'-5"	20'-6"	19'-5"	18'-3"	24'-10"	22'-9"	21'-6"	20'-3"	22'-11"	21'-0"	19'-11"	18'-8"	25'-5"	23'-4"	22'-1"	20'-9"
	16"	24'-6"	22'-4"	21'-2"	19'-10"	27'-1"	24'-10"	23'-5"	22'-0"	25'-0"	22'-11"	21'-8"	20'-4"	27'-9"	25'-5"	24'-1"	22'-8"
LPI 56	11-7/8"	20'-8"	18'-10"	17'-10"	17'-0"	22'-10"	20'-11"	19'-9"	18'-7"	21'-1"	19'-3"	18'-2"	17'-3"	23'-5"	21'-5"	20'-3"	19'-0"
	14"	22'-11"	20'-11"	19'-9"	18'-6"	25'-5"	23'-3"	22'-0"	20'-7"	23'-5"	21'-5"	20'-3"	19'-0"	26'-0"	23'-10"	22'-6"	21'-2"
	16"	24'-11"	22'-9"	21'-6"	20'-2"	27'-8"	25'-3"	23'-11"	22'-5"	25'-6"	23'-4"	22'-1"	20'-8"	28'-4"	25'-11"	24'-6"	23'-0"

23/32" OSB SHEATHING GLUED & NAILED

Series	Depth	No Direct Attached Ceiling								Direct Attached 1/2" Gypsum Ceiling							
		Maximum Simple Spans				Maximum Continuous Spans				Maximum Simple Spans				Maximum Continuous Spans			
		12" oc	16" oc	19.2" oc	24" oc	12" oc	16" oc	19.2" oc	24" oc	12" oc	16" oc	19.2" oc	24" oc	12" oc	16" oc	19.2" oc	24" oc
LPI 18	9-1/2"	15'-9"	14'-11"	14'-4"	13'-2"	17'-1"	16'-2"	15'-2"	13'-7"	16'-3"	15'-3"	14'-4"	13'-2"	17'-7"	16'-7"	15'-2"	13'-7"
	11-7/8"	17'-8"	16'-9"	16'-2"	14'-10"	19'-5"	18'-1"	16'-7"	14'-9"	18'-3"	17'-3"	16'-8"	14'-10"	20'-3"	18'-2"	16'-7"	14'-9"
	14"	19'-7"	18'-3"	17'-7"	16'-10"	21'-8"	20'-2"	19'-3"	17'-4"	20'-4"	19'-0"	18'-2"	17'-5"	22'-7"	21'-0"	19'-7"	17'-4"
LPI 20Plus	9-1/2"	16'-5"	15'-6"	14'-11"	14'-4"	17'-9"	16'-9"	16'-2"	15'-2"	16'-10"	15'-11"	15'-4"	14'-5"	18'-4"	17'-3"	16'-8"	15'-2"
	11-7/8"	18'-6"	17'-4"	16'-9"	16'-1"	20'-5"	19'-0"	18'-2"	17'-5"	19'-1"	17'-10"	17'-3"	16'-6"	21'-2"	19'-9"	18'-10"	17'-7"
	14"	20'-7"	19'-1"	18'-3"	17'-6"	22'-9"	21'-1"	20'-2"	19'-0"	21'-4"	19'-10"	18'-11"	18'-0"	23'-7"	21'-11"	21'-0"	19'-0"
LPI 32Plus	9-1/2"	16'-11"	15'-11"	15'-4"	14'-9"	18'-4"	17'-3"	16'-8"	16'-0"	17'-4"	16'-4"	15'-9"	15'-1"	18'-11"	17'-8"	17'-1"	16'-5"
	11-7/8"	19'-2"	17'-10"	17'-2"	16'-6"	21'-2"	19'-8"	18'-9"	17'-10"	19'-9"	18'-4"	17'-7"	16'-11"	21'-10"	20'-4"	19'-5"	18'-5"
	14"	21'-3"	19'-8"	18'-9"	17'-10"	23'-6"	21'-9"	20'-9"	19'-4"	21'-11"	20'-4"	19'-5"	18'-5"	24'-3"	22'-7"	21'-7"	19'-4"
LPI 36	11-7/8"	19'-9"	18'-3"	17'-7"	16'-10"	21'-10"	20'-3"	19'-4"	18'-4"	20'-4"	18'-10"	18'-0"	17'-3"	22'-6"	20'-11"	19'-11"	18'-11"
	14"	21'-10"	20'-3"	19'-4"	18'-4"	24'-2"	22'-5"	21'-4"	19'-8"	22'-6"	20'-11"	19'-11"	18'-11"	24'-11"	23'-2"	22'-1"	19'-8"
	16"	23'-9"	22'-0"	20'-11"	19'-10"	26'-3"	24'-4"	23'-2"	19'-8"	24'-5"	22'-8"	21'-8"	20'-7"	27'-1"	25'-2"	24'-0"	19'-8"
LPI 42Plus	9-1/2"	18'-0"	17'-0"	16'-4"	15'-8"	19'-11"	18'-6"	17'-8"	17'-0"	18'-6"	17'-4"	16'-8"	16'-0"	20'-5"	19'-0"	18'-1"	17'-4"
	11-7/8"	20'-10"	19'-3"	18'-4"	17'-7"	23'-1"	21'-4"	20'-4"	19'-3"	21'-4"	19'-10"	18'-10"	17'-11"	23'-8"	21'-11"	20'-11"	19'-10"
	14"	23'-2"	21'-5"	20'-5"	19'-4"	25'-8"	23'-8"	22'-7"	21'-5"	23'-9"	22'-0"	21'-0"	19'-10"	26'-4"	24'-5"	23'-3"	22'-1"
LPI 52Plus	11-7/8"	21'-5"	19'-10"	18'-10"	17'-11"	23'-8"	21'-11"	20'-10"	19'-10"	21'-11"	20'-4"	19'-4"	18'-4"	24'-3"	22'-6"	21'-5"	20'-4"
	14"	23'-9"	21'-11"	20'-11"	19'-10"	26'-3"	24'-4"	23'-2"	21'-11"	24'-4"	22'-6"	21'-6"	20'-4"	26'-11"	24'-11"	23'-10"	22'-7"
	16"	25'-10"	23'-11"	22'-9"	21'-6"	28'-7"	26'-5"	25'-2"	23'-10"	26'-6"	24'-6"	23'-4"	22'-2"	29'-3"	27'-2"	25'-11"	24'-6"
LPI 56	11-7/8"	21'-10"	20'-2"	19'-2"	18'-2"	24'-2"	22'-4"	21'-3"	20'-2"	22'-4"	20'-8"	19'-8"	18'-8"	24'-9"	22'-11"	21'-10"	20'-8"
	14"	24'-3"	22'-4"	21'-3"	20'-2"	26'-10"	24'-9"	23'-7"	22'-4"	24'-9"	22'-11"	21'-10"	20'-8"	27'-5"	25'-5"	24'-2"	22'-11"
	16"	26'-4"	24'-3"	23'-1"	21'-10"	29'-1"	26'-11"	25'-7"	24'-2"	26'-11"	24'-11"	23'-8"	22'-5"	29'-10"	27'-7"	26'-4"	24'-9"

DESIGN ASSUMPTIONS:

1. The spans listed are the clear distance between supports. Continuous spans are based on the longest span. The shortest span shall not be less than 50% of the longest span.
2. The spans are based on uniform floor loads only, for standard load duration.
3. These tables reflect the additional stiffness for vibration provided by a 23/32" OSB rated sheathing, or equal, attached as indicated (Nailed Only or Glued & Nailed) to the top flange.
4. Live load deflection is limited to L/360 "bare joist".
5. Total load deflection is limited to L/240 "bare joist".
6. The spans are based on an end bearing length of at least 1-3/4" and an interior bearing length of at least 3-1/2", and are limited to the bearing resistance of an SPF wall plate.

ADDITIONAL NOTES:

1. These spans have been designed to meet the Limit States Design and vibration requirements of the National Building Code of Canada.
2. Web stiffeners are not required for any of the spans in these tables.
3. Web fillers are required for I-joists installed in hangers that do not laterally support the top flange.
4. For conditions not shown, use the Uniform Floor Load (PLF) tables, LP's design software or contact your LP® SolidStart® Engineered Wood Products distributor for assistance.

Floor Span Tables: 5/8" OSB Sheathing

SPECIFIED FLOOR LOADS: 40 PSF LIVE LOAD, 15 PSF DEAD LOAD

TO USE:

1. Select the appropriate table based on the floor system construction.
2. Select the Simple Span or Continuous Span section of the table, as required.
3. Find a span that meets or exceeds the required clear span.
4. Read the corresponding joist series, depth and spacing.

CAUTION: For floor systems that require both simple span and continuous span joists, it is a good idea to check both before selecting a joist. Some conditions are controlled by continuous span rather than simple span.

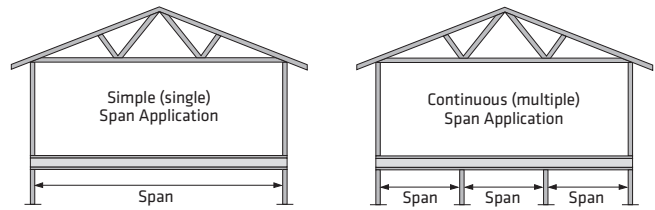

5/8" OSB SHEATHING NAILED ONLY													
Series	Depth	No Direct Attached Ceiling						Direct Attached 1/2" Gypsum Ceiling					
		Maximum Simple Spans			Maximum Continuous Spans			Maximum Simple Spans			Maximum Continuous Spans		
		12" oc	16" oc	19.2" oc	12" oc	16" oc	19.2" oc	12" oc	16" oc	19.2" oc	12" oc	16" oc	19.2" oc
LPI 18	9-1/2"	13'-10"	12'-11"	12'-4"	15'-0"	14'-0"	13'-5"	14'-3"	13'-3"	12'-9"	15'-5"	14'-5"	13'-10"
	11-7/8"	15'-8"	14'-7"	14'-0"	17'-0"	15'-10"	15'-2"	16'-2"	15'-1"	14'-5"	17'-6"	16'-4"	15'-8"
	14"	17'-1"	15'-11"	15'-4"	18'-8"	17'-4"	16'-7"	17'-8"	16'-6"	15'-10"	19'-6"	17'-11"	17'-2"
LPI 20Plus	9-1/2"	14'-7"	13'-8"	13'-1"	15'-10"	14'-9"	14'-2"	15'-0"	14'-0"	13'-5"	16'-3"	15'-2"	14'-7"
	11-7/8"	16'-6"	15'-4"	14'-9"	17'-10"	16'-8"	16'-0"	16'-11"	15'-9"	15'-2"	18'-6"	17'-2"	16'-5"
	14"	18'-0"	16'-9"	16'-1"	19'-11"	18'-3"	17'-6"	18'-8"	17'-3"	16'-7"	20'-8"	19'-0"	18'-0"
LPI 32Plus	9-1/2"	15'-2"	14'-2"	13'-7"	16'-5"	15'-4"	14'-9"	15'-7"	14'-6"	13'-11"	16'-10"	15'-9"	15'-1"
	11-7/8"	17'-1"	15'-11"	15'-3"	18'-7"	17'-3"	16'-7"	17'-6"	16'-4"	15'-8"	19'-3"	17'-9"	17'-0"
	14"	18'-8"	17'-3"	16'-7"	20'-9"	19'-0"	18'-0"	19'-4"	17'-9"	17'-0"	21'-6"	19'-8"	18'-8"
LPI 36	11-7/8"	17'-7"	16'-4"	15'-8"	19'-4"	17'-9"	17'-1"	18'-0"	16'-9"	16'-1"	20'-0"	18'-3"	17'-6"
	14"	19'-5"	17'-9"	17'-1"	21'-6"	19'-8"	18'-8"	20'-0"	18'-3"	17'-6"	22'-2"	20'-4"	19'-3"
	16"	21'-1"	19'-3"	18'-3"	23'-5"	21'-5"	20'-3"	21'-9"	19'-11"	18'-11"	24'-2"	22'-2"	21'-0"
LPI 42Plus	9-1/2"	16'-5"	15'-4"	14'-8"	17'-10"	16'-8"	16'-0"	16'-10"	15'-8"	15'-0"	18'-4"	17'-0"	16'-4"
	11-7/8"	18'-8"	17'-3"	16'-7"	20'-9"	18'-11"	18'-0"	19'-2"	17'-8"	16'-11"	21'-4"	19'-6"	18'-6"
	14"	20'-10"	19'-0"	18'-0"	23'-1"	21'-1"	20'-0"	21'-5"	19'-7"	18'-7"	23'-9"	21'-9"	20'-8"
LPI 52Plus	11-7/8"	19'-3"	17'-9"	17'-0"	21'-5"	19'-7"	18'-7"	19'-10"	18'-1"	17'-4"	21'-11"	20'-1"	19'-1"
	14"	21'-6"	19'-8"	18'-7"	23'-10"	21'-9"	20'-8"	22'-1"	20'-2"	19'-2"	24'-5"	22'-5"	21'-3"
	16"	23'-5"	21'-5"	20'-4"	25'-11"	23'-9"	22'-6"	24'-1"	22'-0"	20'-11"	26'-8"	24'-5"	23'-2"
LPI 56	11-7/8"	19'-9"	18'-0"	17'-3"	21'-11"	20'-0"	19'-0"	20'-3"	18'-6"	17'-8"	22'-6"	20'-7"	19'-6"
	14"	21'-11"	20'-0"	19'-0"	24'-4"	22'-3"	21'-1"	22'-6"	20'-7"	19'-6"	25'-0"	22'-11"	21'-8"
	16"	23'-10"	21'-9"	20'-7"	26'-6"	24'-2"	22'-11"	24'-6"	22'-5"	21'-3"	27'-2"	24'-11"	23'-7"

5/8" OSB SHEATHING GLUED & NAILED													
Series	Depth	No Direct Attached Ceiling						Direct Attached 1/2" Gypsum Ceiling					
		Maximum Simple Spans			Maximum Continuous Spans			Maximum Simple Spans			Maximum Continuous Spans		
		12" oc	16" oc	19.2" oc	12" oc	16" oc	19.2" oc	12" oc	16" oc	19.2" oc	12" oc	16" oc	19.2" oc
LPI 18	9-1/2"	15'-2"	14'-4"	13'-10"	16'-5"	15'-6"	15'-0"	15'-7"	14'-9"	14'-4"	16'-11"	16'-0"	15'-2"
	11-7/8"	17'-0"	16'-1"	15'-7"	18'-6"	17'-5"	16'-7"	17'-7"	16'-1"	15'-1"	19'-3"	18'-0"	16'-7"
	14"	18'-8"	17'-6"	16'-11"	20'-7"	19'-2"	18'-5"	19'-5"	18'-1"	17'-6"	21'-6"	20'-1"	19'-3"
LPI 20Plus	9-1/2"	15'-9"	14'-11"	14'-5"	17'-1"	16'-1"	15'-7"	16'-3"	15'-4"	14'-10"	17'-7"	16'-7"	16'-1"
	11-7/8"	17'-8"	16'-8"	16'-1"	19'-5"	18'-1"	17'-6"	18'-3"	17'-2"	16'-7"	20'-2"	18'-10"	18'-0"
	14"	19'-7"	18'-2"	17'-6"	21'-8"	20'-1"	19'-3"	20'-4"	18'-11"	18'-1"	22'-6"	20'-11"	20'-1"
LPI 32Plus	11-7/8"	18'-9"	17'-6"	17'-6"	21'-8"	20'-1"	19'-3"	20'-4"	18'-11"	18'-1"	22'-6"	20'-11"	20'-1"
	14"	20'-3"	18'-9"	17'-11"	22'-4"	20'-9"	19'-10"	20'-11"	19'-5"	18'-7"	23'-2"	21'-7"	20'-8"
	16"	22'-0"	20'-4"	19'-6"	24'-4"	22'-6"	21'-7"	22'-9"	21'-2"	20'-3"	25'-3"	23'-5"	22'-5"
LPI 36	11-7/8"	18'-9"	17'-6"	16'-11"	20'-9"	19'-3"	18'-5"	19'-5"	18'-0"	17'-5"	21'-6"	19'-11"	19'-1"
	14"	20'-10"	19'-3"	18'-5"	23'-0"	21'-4"	20'-5"	21'-6"	19'-11"	19'-1"	23'-10"	22'-1"	21'-2"
	16"	22'-7"	20'-11"	20'-0"	25'-0"	23'-2"	22'-2"	23'-4"	21'-8"	20'-9"	25'-10"	24'-0"	23'-0"
LPI 42Plus	9-1/2"	17'-4"	16'-4"	15'-9"	19'-0"	17'-8"	17'-1"	17'-9"	16'-8"	16'-1"	19'-6"	18'-1"	17'-6"
	11-7/8"	19'-10"	18'-4"	17'-8"	22'-0"	20'-4"	19'-5"	20'-5"	18'-11"	18'-1"	22'-7"	21'-0"	20'-1"
	14"	22'-1"	20'-5"	19'-6"	24'-5"	22'-7"	21'-7"	22'-8"	21'-0"	20'-1"	25'-2"	23'-4"	22'-3"
LPI 52Plus	11-7/8"	20'-0"	22'-2"	21'-2"	26'-7"	24'-7"	23'-6"	24'-9"	22'-11"	21'-10"	27'-5"	25'-5"	24'-3"
	14"	22'-8"	20'-11"	20'-0"	25'-1"	23'-2"	22'-2"	23'-3"	21'-6"	20'-7"	25'-9"	23'-10"	22'-10"
	16"	24'-8"	22'-9"	21'-9"	27'-3"	25'-2"	24'-1"	25'-4"	23'-5"	22'-5"	28'-0"	26'-0"	24'-10"
LPI 56	11-7/8"	20'-10"	19'-3"	18'-4"	23'-1"	21'-4"	20'-4"	21'-4"	19'-9"	18'-10"	23'-8"	21'-11"	20'-11"
	14"	23'-1"	21'-3"	20'-4"	25'-7"	23'-7"	22'-6"	23'-8"	21'-11"	20'-11"	26'-3"	24'-4"	23'-2"
	16"	25'-1"	23'-1"	22'-1"	27'-9"	25'-8"	24'-5"	25'-9"	23'-10"	22'-8"	28'-6"	26'-5"	25'-2"

DESIGN ASSUMPTIONS:

1. The spans listed are the clear distance between supports. Continuous spans are based on the longest span. The shortest span shall not be less than 50% of the longest span.
2. The spans are based on uniform floor loads only, for standard load duration.
3. These tables reflect the additional stiffness for vibration provided by a 5/8" OSB rated sheathing, or equal, attached as indicated (Nailed Only or Glued & Nailed) to the top flange.
4. Live load deflection is limited to L/360 "bare joist."
5. Total load deflection is limited to L/240 "bare joist."
6. The spans are based on an end bearing length of at least 1-3/4" and an interior bearing length of at least 3-1/2", and are limited to the bearing resistance of an SPF wall plate.

ADDITIONAL NOTES:

1. These spans have been designed to meet the Limit States Design and vibration requirements of the National Building Code of Canada.
2. Web stiffeners are not required for any of the spans in these tables.
3. Web fillers are required for I-joists seated in hangers that do not laterally support the top flange.
4. For conditions not shown, use the Uniform Floor Load (PLF) tables, LP's design software or contact your LP® SolidStart® Engineered Wood Products distributor for assistance.

Floor Span Tables: 3/4" OSB Sheathing

SPECIFIED FLOOR LOADS: 40 PSF LIVE LOAD, 15 PSF DEAD LOAD

TO USE:

1. Select the appropriate table based on the floor system construction.
2. Select the Simple Span or Continuous Span section of the table, as required.
3. Find a span that meets or exceeds the required clear span.
4. Read the corresponding joist series, depth and spacing.

CAUTION: For floor systems that require both simple span and continuous span joists, it is a good idea to check both before selecting a joist. Some conditions are controlled by continuous span rather than simple span.

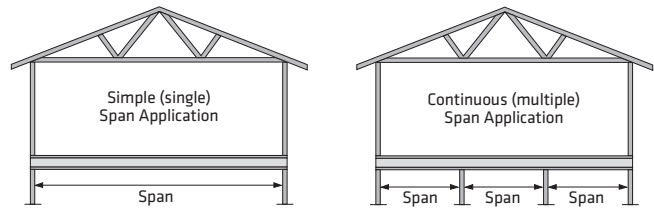

Series		Depth	No Direct Attached Ceiling								Direct Attached 1/2" Gypsum Ceiling							
			Maximum Simple Spans				Maximum Continuous Spans				Maximum Simple Spans				Maximum Continuous Spans			
			12" oc	16" oc	19.2" oc	24" oc	12" oc	16" oc	19.2" oc	24" oc	12" oc	16" oc	19.2" oc	24" oc	12" oc	16" oc	19.2" oc	24" oc
LPI 18	9-1/2"	14'-6"	13'-6"	12'-11"	12'-3"	15'-8"	14'-7"	14'-0"	13'-4"	14'-10"	13'-10"	13'-3"	12'-7"	16'-1"	15'-0"	14'-5"	13'-7"	
	11-7/8"	16'-4"	15'-3"	14'-7"	13'-11"	17'-9"	16'-6"	15'-10"	14'-9"	16'-10"	15'-8"	15'-0"	14'-3"	18'-3"	17'-0"	16'-4"	14'-9"	
	14"	17'-11"	16'-8"	16'-0"	15'-2"	19'-9"	18'-1"	17'-4"	16'-6"	18'-6"	17'-2"	16'-5"	15'-8"	20'-6"	18'-10"	17'-10"	17'-0"	
LPI 20Plus	9-1/2"	15'-3"	14'-3"	13'-8"	12'-11"	16'-7"	15'-5"	14'-9"	14'-1"	15'-8"	14'-7"	14'-0"	13'-3"	17'-0"	15'-10"	15'-2"	14'-5"	
	11-7/8"	17'-3"	16'-1"	15'-4"	14'-7"	18'-10"	17'-5"	16'-8"	15'-10"	17'-8"	16'-6"	15'-9"	15'-0"	19'-6"	17'-11"	17'-1"	16'-3"	
	14"	19'-1"	17'-7"	16'-9"	15'-11"	21'-1"	19'-4"	18'-3"	17'-4"	19'-8"	18'-0"	17'-3"	16'-4"	21'-10"	20'-0"	18'-11"	17'-10"	
LPI 32Plus	9-1/2"	15'-10"	14'-9"	14'-2"	13'-5"	17'-2"	16'-0"	15'-4"	14'-7"	16'-2"	15'-1"	14'-5"	13'-9"	17'-7"	16'-5"	15'-8"	14'-11"	
	11-7/8"	17'-10"	16'-7"	15'-11"	15'-1"	19'-8"	18'-0"	17'-3"	16'-5"	18'-3"	17'-0"	16'-3"	15'-5"	20'-3"	18'-7"	17'-8"	16'-10"	
	14"	19'-10"	18'-1"	17'-3"	16'-5"	22'-0"	20'-1"	19'-0"	17'-10"	20'-5"	18'-8"	17'-9"	16'-10"	22'-9"	20'-9"	19'-7"	18'-5"	
LPI 36	11-7/8"	18'-6"	17'-1"	16'-4"	15'-7"	20'-6"	18'-9"	17'-9"	16'-11"	18'-11"	17'-6"	16'-9"	15'-11"	21'-0"	19'-3"	18'-3"	17'-4"	
	14"	20'-6"	18'-9"	17'-9"	16'-11"	22'-9"	20'-10"	19'-8"	18'-5"	21'-1"	19'-4"	18'-3"	17'-4"	23'-5"	21'-5"	20'-3"	19'-0"	
	16"	22'-4"	20'-5"	19'-3"	18'-1"	24'-9"	22'-8"	21'-5"	19'-8"	23'-0"	21'-0"	19'-10"	18'-7"	25'-6"	23'-4"	22'-1"	19'-8"	
LPI 42Plus	9-1/2"	17'-3"	16'-0"	15'-4"	14'-7"	18'-10"	17'-5"	16'-8"	15'-10"	17'-6"	16'-4"	15'-7"	14'-10"	19'-3"	17'-9"	17'-0"	16'-2"	
	11-7/8"	19'-9"	18'-1"	17'-3"	16'-5"	21'-11"	20'-0"	18'-11"	17'-10"	20'-3"	18'-6"	17'-7"	16'-9"	22'-5"	20'-7"	19'-5"	18'-3"	
	14"	22'-1"	20'-2"	19'-0"	17'-10"	24'-5"	22'-4"	21'-1"	19'-10"	22'-7"	20'-8"	19'-6"	18'-3"	25'-0"	22'-11"	21'-8"	20'-4"	
LPI 52Plus	11-7/8"	20'-5"	18'-8"	17'-9"	16'-10"	22'-7"	20'-8"	19'-7"	18'-4"	20'-10"	19'-1"	18'-1"	17'-2"	23'-1"	21'-2"	20'-1"	18'-10"	
	14"	22'-9"	20'-9"	19'-8"	18'-5"	25'-2"	23'-0"	21'-9"	20'-5"	23'-3"	21'-3"	20'-1"	18'-10"	25'-9"	23'-7"	22'-4"	21'-0"	
	16"	24'-9"	22'-8"	21'-5"	20'-1"	27'-5"	25'-1"	23'-9"	22'-3"	25'-4"	23'-3"	21'-11"	20'-7"	28'-1"	25'-9"	24'-5"	22'-11"	
LPI 56	11-7/8"	20'-11"	19'-1"	18'-0"	17'-2"	23'-2"	21'-2"	20'-0"	18'-9"	21'-4"	19'-6"	18'-5"	17'-5"	23'-8"	21'-8"	20'-6"	19'-3"	
	14"	23'-3"	21'-2"	20'-0"	18'-9"	25'-9"	23'-7"	22'-3"	20'-10"	23'-9"	21'-9"	20'-6"	19'-2"	26'-4"	24'-1"	22'-10"	21'-5"	
	16"	25'-3"	23'-1"	21'-9"	20'-5"	28'-0"	25'-7"	24'-2"	22'-8"	25'-10"	23'-8"	22'-4"	20'-11"	28'-8"	26'-3"	24'-10"	23'-3"	

Series		Depth	No Direct Attached Ceiling								Direct Attached 1/2" Gypsum Ceiling							
			Maximum Simple Spans				Maximum Continuous Spans				Maximum Simple Spans				Maximum Continuous Spans			
			12" oc	16" oc	19.2" oc	24" oc	12" oc	16" oc	19.2" oc	24" oc	12" oc	16" oc	19.2" oc	24" oc	12" oc	16" oc	19.2" oc	24" oc
LPI 18	9-1/2"	16'-0"	15'-1"	14'-4"	13'-2"	17'-3"	16'-4"	15'-2"	13'-7"	16'-5"	15'-3"	14'-4"	13'-2"	17'-10"	16'-7"	15'-2"	13'-7"	
	11-7/8"	17'-11"	16'-11"	16'-4"	14'-10"	19'-9"	18'-2"	16'-7"	14'-9"	18'-7"	17'-5"	16'-8"	14'-10"	20'-6"	18'-2"	16'-7"	14'-9"	
	14"	19'-11"	18'-6"	17'-9"	17'-0"	22'-0"	20'-5"	19'-6"	17'-4"	20'-8"	19'-3"	18'-5"	17'-7"	22'-10"	21'-4"	19'-7"	17'-4"	
LPI 20Plus	9-1/2"	16'-7"	15'-8"	15'-1"	14'-5"	18'-0"	17'-0"	16'-4"	15'-2"	17'-0"	16'-1"	15'-6"	14'-5"	18'-7"	17'-5"	16'-10"	15'-2"	
	11-7/8"	18'-9"	17'-7"	16'-11"	16'-3"	20'-9"	19'-3"	18'-5"	17'-7"	19'-5"	18'-1"	17'-5"	16'-8"	21'-6"	20'-0"	19'-1"	17'-7"	
	14"	20'-11"	19'-5"	18'-6"	17'-8"	23'-1"	21'-5"	20'-5"	19'-0"	21'-7"	20'-1"	19'-2"	18'-3"	23'-11"	22'-3"	21'-3"	19'-0"	
LPI 32Plus	9-1/2"	17'-1"	16'-2"	15'-7"	14'-11"	18'-8"	17'-6"	16'-10"	16'-2"	17'-6"	16'-6"	15'-11"	15'-3"	19'-3"	17'-11"	17'-3"	16'-7"	
	11-7/8"	19'-5"	18'-0"	17'-4"	16'-8"	19'-11"	19'-0"	18'-1"	17'-10"	20'-0"	18'-7"	17'-10"	17'-1"	22'-2"	20'-7"	19'-8"	18'-5"	
	14"	21'-7"	20'-0"	19'-1"	18'-1"	23'-10"	22'-1"	21'-1"	19'-4"	22'-3"	20'-8"	19'-9"	18'-8"	24'-7"	22'-11"	21'-10"	19'-4"	
LPI 36	11-7/8"	20'-0"	18'-7"	17'-9"	17'-0"	22'-2"	20'-6"	19'-7"	18'-7"	20'-7"	19'-1"	18'-3"	17'-5"	22'-10"	21'-2"	20'-3"	19'-2"	
	14"	22'-2"	20'-7"	19'-7"	18'-7"	24'-6"	22'-9"	21'-8"	19'-8"	22'-10"	21'-2"	20'-3"	19'-2"	25'-3"	23'-6"	22'-5"	19'-8"	
	16"	24'-1"	22'-4"	21'-3"	20'-1"	26'-8"	24'-8"	23'-6"	19'-8"	24'-9"	23'-0"	22'-0"	20'-10"	27'-5"	25'-6"	24'-4"	19'-8"	
LPI 42Plus	9-1/2"	18'-4"	17'-2"	16'-6"	15'-10"	20'-3"	18'-9"	17'-11"	17'-2"	18'-9"	17'-6"	16'-10"	16'-2"	20'-9"	19'-3"	18'-4"	17'-6"	
	11-7/8"	21'-2"	19'-7"	18'-8"	17'-9"	23'-5"	21'-8"	20'-8"	19'-6"	21'-8"	20'-1"	19'-2"	18'-1"	24'-0"	22'-3"	21'-3"	20'-1"	
	14"	23'-6"	21'-9"	20'-8"	19'-7"	26'-0"	24'-1"	22'-11"	21'-8"	24'-1"	22'-4"	21'-3"	20'-1"	26'-8"	24'-9"	23'-7"	22'-4"	
LPI 52Plus	11-7/8"	21'-9"	20'-1"	19'-2"	18'-1"	24'-0"	22'-3"	21'-2"	20'-0"	22'-3"	20'-7"	19'-7"	18'-7"	24'-7"	22'-10"	21'-9"	20'-7"	
	14"	24'-1"	22'-3"	21'-2"	20'-1"	26'-8"	24'-8"	23'-6"	22'-2"	24'-8"	22'-10"	21'-9"	20'-7"	27'-3"	25'-4"	24'-1"	22'-10"	
	16"	26'-3"	24'-3"	23'-1"	21'-10"	29'-0"	26'-10"	25'-6"	24'-1"	26'-10"	24'-10"	23'-8"	22'-5"	29'-8"	27'-6"	26'-3"	24'-10"	
LPI 56	11-7/8"	22'-2"	20'-6"	19'-6"	18'-5"	24'-6"	22'-8"	21'-7"	20'-5"	22'-8"	21'-0"	19'-11"	18'-10"	25'-1"	23'-3"	22'-2"	20'-11"	
	14"	24'-7"	22'-8"	21'-7"	20'-5"	27'-2"	25'-1"	23'-11"	22'-7"	25'-1"	23'-3"	22'-1"	20'-11"	27'-10"	25'-9"	24'-6"	23'-2"	
	16"	26'-8"	24'-7"	23'-5"	22'-1"	29'-6"	27'-3"	25'-11"	24'-6"	27'-3"	25'-3"	24'-0"	22'-9"	30'-2"	28'-0"	26'-8"	24'-9"	

DESIGN ASSUMPTIONS:

1. The spans listed are the clear distance between supports. Continuous spans are based on the longest span. The shortest span shall not be less than 50% of the longest span.
2. The spans are based on uniform floor loads only, for standard load duration.
3. These tables reflect the additional stiffness for vibration provided by a 3/4" OSB rated sheathing, or equal, attached as indicated (Nailed Only or Glued & Nailed) to the top flange.
4. Live load deflection is limited to L/360 "bare joist".
5. Total load deflection is limited to L/240 "bare joist".
6. The spans are based on an end bearing length of at least 1-3/4" and an interior bearing length of at least 3-1/2", and are limited to the bearing resistance of an SPF wall plate.

ADDITIONAL NOTES:

1. These spans have been designed to meet the Limit States Design and vibration requirements of the National Building Code of Canada.
2. Web stiffeners are not required for any of the spans in these tables.
3. Web fillers are required for I-joists designed in hangers that do not laterally support the top flange.
4. For conditions not shown, use the Uniform Floor Load (PLF) tables, LP's design software or contact your LP® SolidStart® Engineered Wood Products distributor for assistance.

Uniform Floor Load (PLF) Tables: 9-1/2" and 11-7/8"

TO USE:

1. Select the span required.
2. Compare the factored design total load to the Factored Total Load column.
3. Compare the specified design total load to the Total L/240 column.
4. Compare the specified design live load to the Live L/480 column. For a live load deflection limit of L/360, refer to Additional Note 4 below.
5. Select a product that satisfies all three conditions.

EXAMPLE:

Select an I-joist for a 17'-6" clear span supporting specified loads of 40 psf Live Load and 20 psf Dead Load, spaced 16" oc, at an L/480 deflection limit.

1. Factored Total Load = $(1.50 \times 40 + 1.25 \times 20) \times (16 / 12) = 114$ plf
 Unfactored Total Load = $(40 + 20) \times (16 / 12) = 80$ plf
 Unfactored Live Load = $40 \times (16 / 12) = 54$ plf
2. Select the row corresponding to an 18' span.
3. Select the first joist to exceed all three resistance criteria:
The 9-1/2" LPI 42Plus supports 185 plf Factored Total Load, 108 plf Total L/240 Deflection and 54 plf Live L/480 Deflection resistance.

Span	9-1/2" LPI 18			9-1/2" LPI 20Plus			9-1/2" LPI 32Plus			9-1/2" LPI 42Plus			Span
	Deflection		Factored Total Load	Deflection		Factored Total Load	Deflection		Factored Total Load	Deflection		Factored Total Load	
	Live L/480	Total L/240		Live L/480	Total L/240		Live L/480	Total L/240		Live L/480	Total L/240		
8'	230		300	282		334	321		334		411	8'	
9'	170		268	210		298	241		298	329		367	9'
10'	128		242	160		269	185		269	255		331	10'
11'	99	199	220	125		245	145		245	201		301	11'
12'	78	157	201	99	198	225	115		225	161		276	12'
13'	62	125	172	79	159	208	93	186	208	130		256	13'
14'	51	102	148	65	130	184	76	152	193	107	214	237	14'
15'	42	84	129	53	107	161	63	126	181	89	178	222	15'
16'	35	70	114	44	89	142	52	105	169	74	149	208	16'
17'	29	59	101	37	75	126	44	89	150	63	126	196	17'
18'	25	50	90	32	64	112	37	75	134	54	108	185	18'
19'	21	42	81	27	55	101	32	65	120	46	92	176	19'
20'	18	36	73	23	47	91	28	56	109	40	80	167	20'
21'	16	32	66	20	41	82	24	48	98	35	70	158	21'
22'	-	-	-	-	-	-	-	-	-	30	61	144	22'
23'	-	-	-	-	-	-	-	-	-	27	54	132	23'
24'	-	-	-	-	-	-	-	-	-	-	-	-	24'
25'	-	-	-	-	-	-	-	-	-	-	-	-	25'
26'	-	-	-	-	-	-	-	-	-	-	-	-	26'
27'	-	-	-	-	-	-	-	-	-	-	-	-	27'
28'	-	-	-	-	-	-	-	-	-	-	-	-	28'

Span	11-7/8" LPI 18			11-7/8" LPI 20Plus			11-7/8" LPI 32Plus			11-7/8" LPI 36			11-7/8" LPI 42Plus			11-7/8" LPI 52Plus			11-7/8" LPI 56			Span
	Deflection		Factored Total Load	Deflection		Factored Total Load	Deflection		Factored Total Load	Deflection		Factored Total Load	Deflection		Factored Total Load	Deflection		Factored Total Load	Deflection		Factored Total Load	
	Live L/480	Total L/240		Live L/480	Total L/240		Live L/480	Total L/240		Live L/480	Total L/240		Live L/480	Total L/240		Live L/480	Total L/240		Live L/480	Total L/240		
8'			318			355			355			380			460			521			449	8'
9'	276		284			316			316			339			411			464			401	9'
10'	211		256	257		286			286			306			371			419			362	10'
11'	165		234	202		260	230		260	259		279	318		338	359		382			330	11'
12'	131		215	161		239	184		239	208		256	256		310	289		351	303		303	12'
13'	105		198	131		221	150		221	169		237	210		287	235		325	248		280	13'
14'	86	172	176	107		205	123		205	139		220	173		267	194		302	206		260	14'
15'	71	142	153	89	178	192	102		192	116		206	145		249	162		282	172		243	15'
16'	59	119	135	74	149	180	86	172	180	97		193	122		234	136		265	146		228	16'
17'	50	100	120	63	126	168	73	146	170	83	166	182	103	207	220	115	231	249	124		215	17'
18'	42	85	107	53	107	150	62	125	160	70	141	172	88	177	208	98	197	236	106		203	18'
19'	36	73	96	46	92	135	53	107	152	61	122	163	76	153	198	85	170	223	92	184	193	19'
20'	31	63	87	40	80	122	46	93	141	52	105	155	66	133	188	73	147	212	80	160	183	20'
21'	27	55	79	34	69	111	40	81	128	46	92	148	58	116	179	64	128	202	70	140	175	21'
22'	24	48	72	30	61	101	35	71	116	40	81	141	51	102	171	56	113	193	61	123	167	22'
23'	21	42	66	26	53	92	31	62	106	35	71	135	45	90	164	49	99	185	54	108	160	23'
24'	18	37	60	23	47	85	27	55	98	31	63	129	39	79	157	44	88	177	48	96	153	24'
25'	16	33	55	21	42	78	24	49	90	28	56	124	35	71	145	39	78	170	43	86	147	25'
26'	-	-	-	-	-	-	-	-	-	-	-	-	31	63	134	35	70	163	38	76	141	26'
27'	-	-	-	-	-	-	-	-	-	-	-	-	28	57	125	31	63	152	34	69	136	27'
28'	-	-	-	-	-	-	-	-	-	-	-	-	25	51	116	28	56	141	31	62	131	28'

DESIGN ASSUMPTIONS:

1. Span is the clear distance between supports and is valid for simple or continuous span applications. Continuous spans are based on the longest span. The shortest span shall not be less than 50% of the longest span.
2. The values in the tables are for uniform loads only.
3. Factored Total Load resistance is for standard (100%) load duration.
4. These tables do not reflect any additional stiffness provided by the floor sheathing.
5. Live L/480 Deflection resistance is limited to L/480. Vibration has not been considered.
6. Total L/240 Deflection resistance is limited to L/240. Long term deflection (creep) has not been considered.
7. These tables assume full lateral support of the compression flange. Full support is considered to be a maximum unbraced length of 24'.
8. These tables are based on an end bearing length of at least 1-3/4" and an interior bearing length of at least 3-1/2", and are limited to the bearing capacity for an SPF wall plate.

ADDITIONAL NOTES:

1. These tables have been designed to meet the Limit States Design requirements of the National Building Code of Canada.
2. The tabulated resistances represent the capacity of the member in pounds per lineal foot (plf) of length.
3. The designer shall check the Factored Total Load, the Total L/240 Deflection and the Live L/480 Deflection resistance columns.
4. To design for an L/360 live load deflection, multiply the Live L/480 Deflection values by 1.33 or refer to the Uniform Roof Load (PLF) Tables on pages 12-13.
5. Where the Deflection resistance is blank, the Factored Total Load resistance governs the design.
6. To design a double I-joist, the values in these tables can be doubled, or the design loads on the I-joist may be halved to verify the capacity of each ply. The capacity is additive.
7. Web stiffeners are not required for these spans and loads.
8. Web fillers are required for I-joists seated in hangers that do not laterally support the top flange or for hangers that require nailing into the web.
9. Do not use a product where designated "-" without further analysis by a design professional.

PSF TO PLF CONVERSION

OC Spacing	Load										
	20 psf	25 psf	30 psf	35 psf	40 psf	45 psf	50 psf	55 psf	60 psf	65 psf	
12"	20	25	30	35	40	45	50	55	60	65	
16"	27	34	40	47	54	60	67	74	80	87	
19.2"	32	40	48	56	64	72	80	88	96	104	
24"	40	50	60	70	80	90	100	110	120	130	

TO CONVERT FROM SPECIFIED TO FACTORED TOTAL PLF:

Factored Total plf = 1.50 x Specified Live plf + 1.25 x Specified Dead plf

Uniform Floor Load (PLF) Tables: 14" and 16"

TO USE:

1. Select the span required.
2. Compare the factored design total load to the Factored Total Load column.
3. Compare the specified design total load to the Total L/240 column.
4. Compare the specified design live load to the Live L/480 column. For a live load deflection limit of L/360, refer to Additional Note 4 below.
5. Select a product that satisfies all three conditions.

EXAMPLE:

Select an I-joist for a 20'-6" clear span supporting specified loads of 40 psf Live Load and 20 psf Dead Load, spaced 16" oc, at an L/480 deflection limit.

1. Factored Total Load = $(1.50 \times 40 + 1.25 \times 20) \times (16 / 12) = 114$ plf
 Unfactored Total Load = $(40 + 20) \times (16 / 12) = 80$ plf
 Unfactored Live Load = $40 \times (16 / 12) = 54$ plf
2. Select the row corresponding to an 21' span.
3. Select the first joist to exceed all three resistance criteria:

The 14" LPI 32Plus supports 145 plf Factored Total Load, 116 plf Total L/240 Deflection and 58 plf Live L/480 Deflection resistance.

Span	14" LPI 18			14" LPI 20Plus			14" LPI 32Plus			14" LPI 36			14" LPI 42Plus			14" LPI 52Plus			14" LPI 56			Span
	Deflection		Factored Total Load	Deflection		Factored Total Load	Deflection		Factored Total Load	Deflection		Factored Total Load	Deflection		Factored Total Load	Deflection		Factored Total Load	Deflection		Factored Total Load	
	Live L/480	Total L/240		Live L/480	Total L/240		Live L/480	Total L/240		Live L/480	Total L/240		Live L/480	Total L/240		Live L/480	Total L/240		Live L/480	Total L/240		
14'	125		194	154		216	174		216	195		220	243		277	272		303			261	14'
15'	103		182	128		202	145		202	163		206	204		259	227		283	239		244	15'
16'	87		170	108		190	122		190	137		193	172		243	192		266	203		229	16'
17'	73	147	161	91		179	104		179	117		182	147		229	163		250	173		216	17'
18'	62	125	149	78	156	169	89		169	100		172	126		216	140		237	149		204	18'
19'	53	107	133	67	134	158	76	153	160	86		163	109		205	121		224	129		193	19'
20'	46	93	121	58	116	143	66	133	152	75	150	155	95	190	195	105	210	213	112		184	20'
21'	40	81	109	51	102	130	58	116	145	65	131	148	83	166	186	92	184	203	98		175	21'
22'	35	71	100	44	89	118	51	102	139	57	115	141	73	146	177	80	161	194	87		167	22'
23'	31	62	91	39	78	108	45	90	128	50	101	135	64	129	170	71	142	186	77	154	160	23'
24'	27	55	84	34	69	99	40	80	118	45	90	129	57	115	163	63	126	178	68	137	153	24'
25'	24	49	77	31	62	92	35	71	109	40	80	124	51	102	156	56	112	171	61	122	147	25'
26'	22	44	71	27	55	85	31	63	101	36	72	119	45	91	150	50	100	164	54	109	142	26'
27'	19	39	66	24	49	79	28	57	93	32	64	115	41	82	145	45	90	158	49	98	136	27'
28'	17	35	62	22	44	73	25	51	87	29	58	111	37	74	140	40	81	153	44	88	132	28'
29'	16	32	57	20	40	68	23	46	81	26	52	107	33	67	130	36	73	148	40	80	127	29'
30'	14	29	54	18	36	64	21	42	76	23	47	104	30	61	122	33	67	143	36	73	123	30'
31'	-	-	-	-	-	-	-	-	-	-	-	-	27	55	114	30	61	138	33	66	119	31'
32'	-	-	-	-	-	-	-	-	-	-	-	-	25	50	107	27	55	130	30	60	115	32'
33'	-	-	-	-	-	-	-	-	-	-	-	-	23	46	101	25	50	122	27	55	112	33'
34'	-	-	-	-	-	-	-	-	-	-	-	-	21	42	95	23	46	115	25	51	108	34'

Span	16" LPI 20Plus			16" LPI 32Plus			16" LPI 36			16" LPI 42Plus			16" LPI 52Plus			16" LPI 56			Span		
	Deflection		Factored Total Load	Deflection		Factored Total Load	Deflection		Factored Total Load	Deflection		Factored Total Load	Deflection		Factored Total Load	Deflection		Factored Total Load			
	Live L/480	Total L/240		Live L/480	Total L/240		Live L/480	Total L/240		Live L/480	Total L/240		Live L/480	Total L/240		Live L/480	Total L/240			Live L/480	Total L/240
14'	204		219			219			220			286			304			261			14'
15'	171		205	190		205			206	267		267			284			244			15'
16'	144		192	161		192	179		193	227		251	252		267			229			16'
17'	122		181	137		181	153		182	194		236	215		251			216			17'
18'	105		171	117		171	131		172	167		223	185		238	194		204			18'
19'	90		162	101		162	113		163	145		212	160		225	169		193			19'
20'	78		154	88		154	99		155	126		201	139		214	147		184			20'
21'	68	137	147	77		147	86		148	110		192	122		204	129		175			21'
22'	60	121	136	68	136	141	76		141	97		183	107		195	114		167			22'
23'	53	106	124	60	120	134	67	134	135	86	173	175	95		187	101		160			23'
24'	47	94	114	53	106	129	59	119	129	76	153	168	84	168	179	90		153			24'
25'	42	84	105	47	95	124	53	106	124	68	137	161	75	150	172	80		147			25'
26'	37	75	97	42	85	117	47	95	119	61	123	155	67	134	165	72		142			26'
27'	33	67	90	38	76	108	42	85	115	55	110	150	60	121	159	65	130	137	27		27'
28'	30	61	84	34	69	101	38	77	111	49	99	144	54	109	153	58	117	132	28		28'
29'	27	55	78	31	62	94	35	70	107	45	90	139	49	98	148	53	106	127	29		29'
30'	25	50	73	28	56	88	31	63	104	41	82	135	44	89	143	48	97	123	30		30'
31'	22	45	68	25	51	82	28	57	100	37	74	130	40	81	139	44	88	119	31		31'
32'	20	41	64	23	47	77	26	52	97	34	68	124	37	74	134	40	80	115	32		32'
33'	19	38	60	21	43	72	24	48	94	31	62	117	34	68	130	37	74	112	33		33'
34'	17	34	57	19	39	68	22	44	91	28	57	110	31	62	127	33	67	109	34		34'

DESIGN ASSUMPTIONS:

1. Span is the clear distance between supports and is valid for simple or continuous span applications. Continuous spans are based on the longest span. The shortest span shall not be less than 50% of the longest span.
2. The values in the tables are for uniform loads only.
3. Factored Total Load resistance is for standard (100%) load duration.
4. These tables do not reflect any additional stiffness provided by the floor sheathing.
5. Live L/480 Deflection resistance is limited to L/480. Vibration has not been considered.
6. Total L/240 Deflection resistance is limited to L/240. Long term deflection (creep) has not been considered.
7. These tables assume full lateral support of the compression flange. Full support is considered to be a maximum unbraced length of 24'.
8. These tables are based on an end bearing length of at least 1-3/4" and an interior bearing length of at least 3-1/2", and are limited to the bearing capacity for an SPF wall plate.

ADDITIONAL NOTES:

1. These tables have been designed to meet the Limit States Design requirements of the National Building Code of Canada.
2. The tabulated resistances represent the capacity of the member in pounds per lineal foot (plf) of length.
3. The designer shall check the Factored Total Load, the Total L/240 Deflection and the Live L/480 Deflection resistance columns.
4. To design for an L/360 live load deflection, multiply the Live L/480 Deflection values by 1.33 or refer to the Uniform Roof Load (PLF) Tables on pages 12-13.
5. Where the Deflection resistance is blank, the Factored Total Load resistance governs the design.
6. To design a double I-joist, the values in these tables can be doubled, or the design loads on the I-joist may be halved to verify the capacity of each ply. The capacity is additive.
7. Web stiffeners are not required for these spans and loads.
8. Web fillers are required for I-joists seated in hangers that do not laterally support the top flange or for hangers that require nailing into the web.
9. Do not use a product where designated "-" without further analysis by a design professional.

PSF TO PLF CONVERSION

OC Spacing	Load										
	20 psf	25 psf	30 psf	35 psf	40 psf	45 psf	50 psf	55 psf	60 psf	65 psf	
12"	20	25	30	35	40	45	50	55	60	65	
16"	27	34	40	47	54	60	67	74	80	87	
19.2"	32	40	48	56	64	72	80	88	96	104	
24"	40	50	60	70	80	90	100	110	120	130	

TO CONVERT FROM SPECIFIED TO FACTORED TOTAL PLF:
 Factored Total plf = 1.50 x Specified Live plf + 1.25 x Specified Dead plf

Uniform Roof Load (PLF) Tables: 9-1/2" and 11-7/8"

TO USE:

- Select the span required. For roofs with a slope of 2:12 or greater, the horizontal span shall be multiplied by the appropriate roof slope adjustment factor from the table at the bottom of this page.
- Compare the factored design total load to the Factored Total Load column.
- Compare the specified design total load to the Total L/180 column.
- Compare the specified design live load to the Live L/360 column. For a live load deflection limit of L/480 or L/240, refer to Additional Note 5 below.
- Select a product that satisfies all three conditions.

EXAMPLE:

- Select an I-joist for a 12'-8" horizontal clear span supporting 45 psf Snow (Live) Load and 15 psf Dead Load, spaced 24" oc, with a roof slope of 6:12, at an L/360 deflection limit.
- Factored Total Load = $(1.50 \times 45 + 1.25 \times 15) \times (24 / 12) = 173$ plf
 Unfactored Total Load = $(45 + 15) \times (24 / 12) = 120$ plf
 Unfactored Live Load = $45 \times (24 / 12) = 90$ plf
 - Sloped Span = $(12 + 8/12) \times 1.118 = 14.16'$
 - Select the row corresponding to a 15' span.
 - Select the first joist to exceed all three resistance criteria:
The 9-1/2" LPI 42Plus supports 222 plf Factored Total Load and 118 plf Live L/360 Deflection. Total L/180 Deflection does not control.

Span	9-1/2" LPI 18			9-1/2" LPI 20Plus			9-1/2" LPI 32Plus			9-1/2" LPI 42Plus			Span
	Deflection		Factored Total Load	Deflection		Factored Total Load	Deflection		Factored Total Load	Deflection		Factored Total Load	
	Live L/360	Total L/180		Live L/360	Total L/180		Live L/360	Total L/180		Live L/360	Total L/180		
8'			300			334			334			411	8'
9'	226		268	281		298			298			367	9'
10'	171		242	214		269	247		269			331	10'
11'	132		220	167		245	193		245	268		301	11'
12'	104		201	132		225	154		225	214		276	12'
13'	83	167	172	106		208	124		208	174		256	13'
14'	68	136	148	86	173	184	101		193	143		237	14'
15'	56	112	129	71	143	161	84	168	181	118		222	15'
16'	46	93	114	59	119	142	70	140	169	99	199	208	16'
17'	39	78	101	50	100	126	59	118	150	84	168	196	17'
18'	33	66	90	42	85	112	50	101	134	72	144	185	18'
19'	28	57	81	36	73	101	43	86	120	61	123	176	19'
20'	24	49	73	31	63	91	37	75	109	53	107	167	20'
21'	21	42	66	27	55	82	32	65	98	46	93	158	21'
22'	18	37	60	24	48	75	28	57	90	40	81	144	22'
23'	16	32	55	21	42	69	25	50	82	36	72	132	23'
24'	14	29	51	18	37	63	22	44	75	31	63	121	24'
25'	12	25	47	16	33	58	19	39	70	28	56	112	25'
26'	11	22	43	14	29	54	17	35	64	25	50	104	26'
27'	10	20	40	13	26	50	15	31	60	22	45	96	27'
28'	9	18	37	11	23	46	14	28	55	20	40	89	28'

Span	11-7/8" LPI 18			11-7/8" LPI 20Plus			11-7/8" LPI 32Plus			11-7/8" LPI 36			11-7/8" LPI 42Plus			11-7/8" LPI 52Plus			11-7/8" LPI 56			Span
	Deflection		Factored Total Load	Deflection		Factored Total Load	Deflection		Factored Total Load	Deflection		Factored Total Load	Deflection		Factored Total Load	Deflection		Factored Total Load	Deflection		Factored Total Load	
	Live L/360	Total L/180		Live L/360	Total L/180		Live L/360	Total L/180		Live L/360	Total L/180		Live L/360	Total L/180		Live L/360	Total L/180		Live L/360	Total L/180		
8'			318			355			355			380			460			521			449	8'
9'			284			316			316			339			411			464			401	9'
10'			256			286			286			306			371			419			362	10'
11'	220		234			260			260			279			338			382			330	11'
12'	174		215	215		239			239			256			310			351			303	12'
13'	141		198	174		221	200		221	226		237	280		287	314		325			280	13'
14'	115		176	143		205	164		205	186		220	231		267	259		302			260	14'
15'	95		153	118		192	137		192	155		206	193		249	216		282	230		243	15'
16'	79		135	99		180	115		180	130		193	163		234	181		265	194		228	16'
17'	67		120	84	168	168	97		170	110		182	138		220	154		249	165		215	17'
18'	57		107	71	143	150	83		160	94		172	118		208	131		236	142		203	18'
19'	48		96	61	123	135	71	143	152	81	163	163	102		198	113		223	122		193	19'
20'	42	84	87	53	106	122	62	124	141	70	141	155	88	177	188	98	196	212	106		183	20'
21'	36	73	79	46	92	111	54	108	128	61	123	148	77	155	179	85	171	202	93		175	21'
22'	32	64	72	40	81	101	47	94	116	54	108	141	68	136	171	75	150	193	82	164	167	22'
23'	28	56	66	35	71	92	41	83	106	47	95	135	60	120	164	66	132	185	72	144	160	23'
24'	25	50	60	31	63	85	37	74	98	42	84	129	53	106	157	58	117	177	64	128	153	24'
25'	22	44	55	28	56	78	32	65	90	37	75	124	47	94	145	52	104	170	57	114	147	25'
26'	19	39	51	25	50	72	29	58	83	33	67	119	42	84	134	46	93	163	51	102	141	26'
27'	17	35	48	22	45	67	26	52	77	30	60	115	38	76	125	42	84	152	46	92	136	27'
28'	15	31	44	20	40	62	23	47	72	27	54	107	34	68	116	37	75	141	41	83	131	28'

DESIGN ASSUMPTIONS:

- Span is the clear distance between supports and is valid for simple or continuous span applications. Continuous spans are based on the longest span. The shortest span shall not be less than 50% of the longest span.
- The values in the tables are for uniform loads only.
- Factored Total Load resistance is for standard (100%) load duration.
- These tables do not reflect any additional stiffness provided by the floor sheathing.
- Live L/360 Deflection resistance is limited to L/360. Vibration has not been considered.
- Total L/180 Deflection resistance is limited to L/180. Long term deflection (creep) has not been considered.
- These tables assume full lateral support of the compression flange. Full support is considered to be a maximum unbraced length of 24'.
- These tables are based on an end bearing length of at least 1-3/4" and an interior bearing length of at least 3-1/2", and are limited to the bearing capacity for an SPF wall plate.

ADDITIONAL NOTES:

- These tables have been designed to meet the Limit States Design requirements of the National Building Code of Canada.
- The tabulated resistances represent the capacity of the member in pounds per lineal foot (plf) of length.
- For roofs with a slope of 2:12 or greater, the horizontal span shall be multiplied by the appropriate slope adjustment factor from the table at the bottom of this page. Roof joists shall have a minimum slope of 1/4" per foot (1/4:12) for positive drainage.
- The designer shall check the Factored Total Load, the Total L/180 Deflection and the Live L/360 Deflection resistance columns.
- To design for an L/240 live load deflection, multiply the Live L/360 Deflection values by 1.5. To design for a L/480 live load deflection, multiply the Live L/360 Deflection values by 0.75 or refer to the Uniform Floor Load (PLF) Tables on pages 10-11.
- Where the Deflection resistance is blank, the Factored Total Load resistance governs the design.
- To design a double I-joist, the values in these tables can be doubled, or the design loads on the I-joist may be halved to verify the capacity of each ply. The capacity is additive.
- Web stiffeners are not required for these spans and loads.
- Web fillers are required for I-joists seated in hangers that do not laterally support the top flange or for hangers that require nailing into the web.
- Do not use a product where designated "-" without further analysis by a design professional.

ROOF PITCH ADJUSTMENT FACTORS											
Roof Pitch	2:12	3:12	4:12	5:12	6:12	7:12	8:12	9:12	10:12	11:12	12:12
Factor	1.014	1.031	1.054	1.083	1.118	1.158	1.202	1.250	1.302	1.357	1.414

Uniform Roof Load (PLF) Tables: 14" and 16"

TO USE:

- Select the span required. For roofs with a slope of 2:12 or greater, the horizontal span shall be multiplied by the appropriate roof slope adjustment factor from the table at the bottom of this page.
- Compare the factored design total load to the Factored Total Load column.
- Compare the specified design total load to the Total L/180 column.
- Compare the specified design live load to the Live L/360 column. For a live load deflection limit of L/480 or L/240, refer to Additional Note 5 below.
- Select a product that satisfies all three conditions.

EXAMPLE:

- Select an I-joist for a 17'-8" horizontal clear span supporting 45 psf Snow (Live) Load and 15 psf Dead Load, spaced 24" oc, with a roof slope of 6:12, at an L/360 deflection limit.
- Factored Total Load = $(1.50 \times 45 + 1.25 \times 15) \times (24 / 12) = 173$ plf
 Unfactored Total Load = $(45 + 15) \times (24 / 12) = 120$ plf
 Unfactored Live Load = $45 \times (24 / 12) = 90$ plf
 - Sloped Span = $(17 + 8/12) \times 1.118 = 19.75'$
 - Select the row corresponding to a 20' span.
 - Select the first joist to exceed all three resistance criteria:
The 14" LPI 42Plus supports 195 plf Factored Total Load and 126 plf Live L/360 Deflection. Total L/180 Deflection does not control.

Span	14" LPI 18			14" LPI 20Plus			14" LPI 32Plus			14" LPI 36			14" LPI 42Plus			14" LPI 52Plus			14" LPI 56			Span
	Deflection		Factored Total Load	Deflection		Factored Total Load	Deflection		Factored Total Load	Deflection		Factored Total Load	Deflection		Factored Total Load	Deflection		Factored Total Load	Deflection		Factored Total Load	
	Live L/360	Total L/180		Live L/360	Total L/180		Live L/360	Total L/180		Live L/360	Total L/180		Live L/360	Total L/180		Live L/360	Total L/180		Live L/360	Total L/180		
14'	167		194	205		216			216			220			277			303			261	14'
15'	138		182	171		202	193		202			206			259			283			244	15'
16'	116		170	144		190	163		190	183		193	230		243	256		266			229	16'
17'	98		161	122		179	138		179	156		182	196		229	218		250			216	17'
18'	83		149	104		169	118		169	133		172	168		216	187		237	199		204	18'
19'	71		133	89		158	102		160	115		163	145		205	161		224	172		193	19'
20'	62		121	77		143	89		152	100		155	126		195	140		213	150		184	20'
21'	54	108	109	68		130	77		145	87		148	111		186	122		203	131		175	21'
22'	47	94	100	59		118	68	136	139	76		141	97		177	107		194	116		167	22'
23'	41	83	91	52	105	108	60	120	128	67		135	86		170	95		186	102		160	23'
24'	36	73	84	46	93	99	53	106	118	60	120	129	76	153	163	84	168	178	91		153	24'
25'	32	65	77	41	82	92	47	95	109	53	107	124	68	136	156	75	150	171	81		147	25'
26'	29	58	71	37	74	85	42	85	101	48	96	119	61	122	150	67	134	164	73		142	26'
27'	26	52	66	33	66	79	38	76	93	43	86	115	55	110	145	60	120	158	65	131	136	27'
28'	23	47	62	29	59	73	34	68	87	38	77	111	49	99	140	54	108	153	59	118	132	28'
29'	21	42	57	27	54	68	31	62	81	35	70	107	44	89	130	49	98	148	53	107	127	29'
30'	19	38	54	24	49	64	28	56	76	31	63	104	40	81	122	44	89	143	48	97	123	30'
31'	17	35	50	22	44	60	25	51	71	28	57	100	37	74	114	40	81	138	44	88	119	31'
32'	16	32	47	20	40	56	23	46	66	26	52	97	33	67	107	37	74	130	40	81	115	32'
33'	14	29	44	18	37	53	21	42	62	24	48	93	30	61	101	33	67	122	37	74	112	33'
34'	13	26	42	17	34	50	19	39	59	22	44	88	28	56	95	31	62	115	34	68	108	34'

Span	16" LPI 20Plus			16" LPI 32Plus			16" LPI 36			16" LPI 42Plus			16" LPI 52Plus			16" LPI 56			Span		
	Deflection		Factored Total Load	Deflection		Factored Total Load	Deflection		Factored Total Load	Deflection		Factored Total Load	Deflection		Factored Total Load	Deflection		Factored Total Load			
	Live L/360	Total L/180		Live L/360	Total L/180		Live L/360	Total L/180		Live L/360	Total L/180		Live L/360	Total L/180		Live L/360	Total L/180			Live L/360	Total L/180
14'			219			219			220			286			304			261			14'
15'			205			205			206			267			284			244			15'
16'			192			192			193			251			267			229			16'
17'			181			181			182			236			251			216			17'
18'	140		171	157		171			172	223		223			238			204			18'
19'	121		162	135		162	151		163	193		212	213		225			193			19'
20'	105		154	118		154	132		155	168		201	186		214			184			20'
21'	91		147	103		147	115		148	147		192	162		204	173		175			21'
22'	80		136	90		141	101		141	130		183	143		195	152		167			22'
23'	71		124	80		134	89		135	115		175	126		187	135		160			23'
24'	63		114	71		129	79		129	102		168	112		179	120		153			24'
25'	56		105	63		124	71		124	91		161	100		172	107		147			25'
26'	50		97	56	113	117	63		119	82		155	89		165	96		142			26'
27'	45	90	90	51	102	108	57	114	115	73	147	150	80		159	86		137			27'
28'	40	81	84	46	92	101	51	103	111	66	133	144	72	145	153	78		132			28'
29'	36	73	78	41	83	94	46	93	107	60	120	139	65	131	148	71		127			29'
30'	33	66	73	37	75	88	42	84	104	54	109	135	59	119	143	64		123			30'
31'	30	60	68	34	68	82	38	77	100	49	99	130	54	109	139	58	117	119			31'
32'	27	55	64	31	62	77	35	70	97	45	91	124	49	99	134	53	107	115			32'
33'	25	50	60	28	57	72	32	64	94	41	83	117	45	91	130	49	98	112			33'
34'	23	46	57	26	52	68	29	59	91	38	76	110	41	83	127	45	90	109			34'

DESIGN ASSUMPTIONS:

- Span is the clear distance between supports and is valid for simple or continuous span applications. Continuous spans are based on the longest span. The shortest span shall not be less than 50% of the longest span.
- The values in the tables are for uniform loads only.
- Factored Total Load resistance is for standard (100%) load duration.
- These tables do not reflect any additional stiffness provided by the floor sheathing.
- Live L/360 Deflection resistance is limited to L/360. Vibration has not been considered.
- Total L/180 Deflection resistance is limited to L/180. Long term deflection (creep) has not been considered.
- These tables assume full lateral support of the compression flange. Full support is considered to be a maximum unbraced length of 24'.
- These tables are based on an end bearing length of at least 1-3/4" and an interior bearing length of at least 3-1/2", and are limited to the bearing capacity for an SPF wall plate.

ADDITIONAL NOTES:

- These tables have been designed to meet the Limit States Design requirements of the National Building Code of Canada.
- The tabulated resistances represent the capacity of the member in pounds per lineal foot (plf) of length.
- For roofs with a slope of 2:12 or greater, the horizontal span shall be multiplied by the appropriate slope adjustment factor from the table at the bottom of this page. Roof joists shall have a minimum slope of 1/4" per foot (1/4:12) for positive drainage.
- The designer shall check the Factored Total Load, the Total L/180 Deflection and the Live L/360 Deflection resistance columns.
- To design for an L/240 live load deflection, multiply the Live L/360 Deflection values by 1.5. To design for a L/480 live load deflection, multiply the Live L/360 Deflection values by 0.75 or refer to the Uniform Floor Load (PLF) Tables on pages 10-11.
- Where the Deflection resistance is blank, the Factored Total Load resistance governs the design.
- To design a double I-joist, the values in these tables can be doubled, or the design loads on the I-joist may be halved to verify the capacity of each ply. The capacity is additive.
- Web stiffeners are not required for these spans and loads.
- Web fillers are required for I-joists seated in hangers that do not laterally support the top flange or for hangers that require nailing into the web.
- Do not use a product where designated "-" without further analysis by a design professional.

ROOF PITCH ADJUSTMENT FACTORS											
Roof Pitch	2:12	3:12	4:12	5:12	6:12	7:12	8:12	9:12	10:12	11:12	12:12
Factor	1.014	1.031	1.054	1.083	1.118	1.158	1.202	1.250	1.302	1.357	1.414

Roof Span Tables: Low Pitch (6:12 or less) for 20, 25 and 30 psf Load

TO USE:

1. Select the appropriate set of tables based on roof pitch.
2. Select the section of that table that corresponds to the specified roof live or snow load.
3. Find a span that meets or exceeds the design span for the appropriate specified roof dead load (15 psf or 20 psf).
4. Read the corresponding series, depth and spacing.

DESIGN ASSUMPTIONS:

1. The spans listed are the horizontal clear distance between supports and are valid for simple or continuous span applications. Continuous spans are based on the longest span. The shortest span shall not be less than 50% of the longest span.
2. The spans are based on uniform gravity loads only as listed for each table, including the effects of a 300 lb concentrated load. These spans have not been evaluated for wind.
3. These tables do not reflect any additional stiffness provided by the roof sheathing.
4. Live load deflection is limited to L/360.
5. Total load deflection is limited to L/180.
6. The spans are based on an end bearing length of at least 1-3/4" and an interior bearing length of at least 3-1/2", and are limited to the bearing capacity for an SPF wall plate.

ADDITIONAL NOTES:

1. Web stiffeners are not required for the Roof Span tables except when using a "bird's mouth" detail for the low-end bearing.
2. Web fillers are required for I-joists seated in hangers that do not laterally support the top flange or for hangers that require nailing into the web.
3. L/360 represents the maximum deflection allowed per code for roof joists supporting plaster or gypsum ceilings. Verify deflection limits with local code requirements.
4. Roof joists must have a minimum pitch of 1/4" per foot (1/4:12) for positive drainage.
5. Roof applications in high wind areas require special analysis which may reduce spans and may require bracing of the bottom flange and special connectors to resist uplift.
6. For conditions not shown, use the Uniform Roof Load (PLF) tables, LP's design software or contact your LP® SolidStart® Engineered Wood Products distributor for assistance.

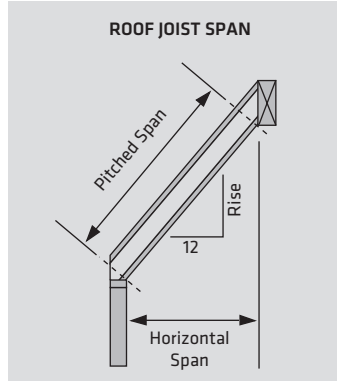

ACTUAL DEFLECTION BASED ON SPAN AND LIMIT			
Span (ft)	L/360	L/240	L/180
10'	5/16"	1/2"	11/16"
12'	3/8"	5/8"	13/16"
14'	7/16"	11/16"	15/16"
16'	9/16"	13/16"	1-1/16"
18'	5/8"	7/8"	1-3/16"
20'	11/16"	1"	1-5/16"
22'	3/4"	1-1/8"	1-7/16"
24'	13/16"	1-3/16"	1-5/8"
26'	7/8"	1-5/16"	1-3/4"
28'	15/16"	1-3/8"	1-7/8"
30'	1"	1-1/2"	2"

* Deflections rounded to the nearest 1/16"

SPECIFIED ROOF LIVE OR SNOW LOAD (STANDARD DURATION)	20 psf Roof Live or Snow	Series	Depth	16" oc		19.2" oc		24" oc	
		LPI 18	9-1/2"	15 psf	20 psf	15 psf	20 psf	15 psf	20 psf
				Specified Dead Load →	15 psf	20 psf	15 psf	20 psf	15 psf
20 psf Roof Live or Snow	LPI 18	9-1/2"	18'-9"	18'-5"	17'-7"	17'-3"	16'-4"	15'-8"	
		11-7/8"	22'-8"	21'-0"	20'-8"	19'-1"	18'-5"	17'-1"	
		14"	25'-11"	24'-9"	24'-4"	22'-7"	21'-10"	20'-2"	
	LPI 20Plus	9-1/2"	20'-6"	20'-1"	19'-3"	18'-10"	17'-10"	17'-5"	
		11-7/8"	24'-7"	24'-1"	23'-1"	22'-7"	21'-4"	20'-3"	
		14"	28'-1"	26'-11"	26'-5"	24'-7"	23'-9"	22'-0"	
	LPI 32Plus	9-1/2"	21'-9"	21'-4"	20'-5"	20'-0"	18'-10"	18'-6"	
		11-7/8"	25'-11"	25'-5"	24'-4"	23'-11"	22'-7"	21'-10"	
		14"	29'-6"	28'-11"	27'-8"	26'-10"	25'-8"	23'-11"	
	LPI 36	9-1/2"	27'-2"	26'-8"	25'-6"	25'-0"	23'-7"	23'-2"	
		11-7/8"	30'-9"	30'-2"	28'-11"	28'-4"	26'-9"	26'-3"	
		14"	34'-0"	33'-4"	31'-11"	31'-4"	29'-7"	27'-10"	
	LPI 42Plus	9-1/2"	24'-8"	24'-2"	23'-2"	22'-8"	21'-5"	21'-0"	
		11-7/8"	29'-6"	28'-11"	27'-8"	27'-2"	25'-7"	25'-1"	
		14"	33'-6"	32'-10"	31'-6"	30'-10"	29'-2"	28'-7"	
	LPI 52Plus	9-1/2"	30'-6"	29'-11"	28'-7"	28'-1"	26'-6"	26'-0"	
		11-7/8"	34'-7"	33'-11"	32'-6"	31'-10"	30'-1"	29'-6"	
		14"	38'-3"	37'-7"	36'-0"	35'-3"	33'-4"	32'-8"	
	LPI 56	9-1/2"	31'-6"	30'-11"	29'-7"	29'-0"	27'-5"	26'-10"	
		11-7/8"	35'-8"	35'-0"	33'-6"	32'-10"	31'-0"	30'-5"	
		14"	39'-5"	38'-8"	37'-0"	36'-4"	34'-3"	31'-2"	
	25 psf Snow	LPI 18	9-1/2"	17'-4"	17'-4"	16'-4"	16'-4"	15'-1"	14'-11"
			11-7/8"	20'-11"	20'-0"	19'-3"	18'-2"	17'-3"	16'-3"
			14"	24'-0"	23'-7"	22'-6"	21'-6"	20'-4"	19'-2"
		LPI 20Plus	9-1/2"	19'-0"	19'-0"	17'-10"	17'-10"	16'-5"	16'-5"
			11-7/8"	22'-9"	22'-9"	21'-4"	21'-4"	19'-9"	19'-4"
			14"	26'-0"	25'-8"	24'-5"	23'-5"	22'-2"	20'-11"
		LPI 32Plus	9-1/2"	20'-1"	20'-1"	18'-10"	18'-10"	17'-5"	17'-5"
			11-7/8"	24'-0"	24'-0"	22'-7"	22'-7"	20'-10"	20'-9"
			14"	27'-4"	27'-4"	25'-8"	25'-6"	23'-9"	22'-10"
LPI 36		9-1/2"	25'-2"	25'-2"	23'-7"	23'-7"	21'-10"	21'-10"	
		11-7/8"	28'-6"	28'-6"	26'-9"	26'-9"	24'-9"	24'-9"	
		14"	31'-6"	31'-6"	29'-7"	29'-7"	27'-4"	24'-11"	
LPI 42Plus		9-1/2"	22'-10"	22'-10"	21'-5"	21'-5"	19'-9"	19'-9"	
		11-7/8"	27'-3"	27'-3"	25'-7"	25'-7"	23'-8"	23'-8"	
		14"	31'-1"	31'-1"	29'-2"	29'-2"	27'-0"	27'-0"	
LPI 52Plus		9-1/2"	34'-5"	34'-5"	32'-4"	32'-4"	29'-11"	29'-11"	
		11-7/8"	28'-3"	28'-3"	26'-6"	26'-6"	24'-6"	24'-6"	
		14"	32'-0"	32'-0"	30'-1"	30'-1"	27'-10"	27'-10"	
LPI 56		9-1/2"	35'-6"	35'-6"	33'-4"	33'-4"	30'-10"	30'-10"	
		11-7/8"	29'-2"	29'-2"	27'-5"	27'-5"	25'-4"	25'-4"	
		14"	33'-1"	33'-1"	31'-0"	31'-0"	28'-9"	28'-3"	
30 psf Snow		LPI 18	9-1/2"	16'-4"	16'-4"	15'-4"	15'-4"	14'-2"	14'-1"
			11-7/8"	19'-8"	18'-11"	18'-2"	17'-3"	16'-2"	15'-5"
			14"	22'-6"	22'-4"	21'-2"	20'-4"	19'-2"	18'-2"
		LPI 20Plus	9-1/2"	17'-10"	17'-10"	16'-8"	16'-8"	15'-5"	15'-5"
			11-7/8"	21'-4"	21'-4"	20'-0"	20'-0"	18'-6"	18'-3"
			14"	24'-5"	24'-4"	22'-11"	22'-2"	20'-10"	19'-10"
		LPI 32Plus	9-1/2"	27'-2"	26'-1"	25'-0"	23'-9"	22'-4"	21'-3"
			11-7/8"	18'-10"	18'-10"	17'-8"	17'-8"	16'-4"	16'-4"
			14"	22'-7"	22'-7"	21'-2"	21'-2"	19'-7"	19'-7"
	LPI 36	9-1/2"	25'-8"	25'-8"	24'-1"	24'-1"	22'-3"	21'-2"	
		11-7/8"	28'-5"	28'-5"	26'-8"	26'-0"	23'-6"	21'-3"	
		14"	33'-7"	33'-7"	32'-2"	32'-2"	29'-6"	28'-6"	
	LPI 42Plus	9-1/2"	26'-9"	26'-9"	25'-1"	25'-1"	23'-3"	22'-2"	
		11-7/8"	21'-5"	21'-5"	20'-1"	20'-1"	18'-7"	18'-7"	
		14"	29'-2"	29'-2"	27'-4"	27'-4"	25'-4"	25'-4"	
	LPI 52Plus	9-1/2"	32'-4"	32'-4"	30'-4"	30'-4"	28'-1"	28'-1"	
		11-7/8"	26'-6"	26'-6"	24'-11"	24'-11"	23'-0"	23'-0"	
		14"	30'-1"	30'-1"	28'-3"	28'-3"	26'-2"	26'-2"	
	LPI 56	9-1/2"	33'-4"	33'-4"	31'-3"	31'-3"	28'-11"	28'-11"	
		11-7/8"	27'-5"	27'-5"	25'-8"	25'-8"	23'-9"	23'-9"	
		14"	31'-0"	31'-0"	29'-2"	29'-2"	26'-11"	25'-4"	
	30 psf Snow	LPI 56	9-1/2"	34'-3"	34'-3"	32'-2"	31'-9"	28'-1"	25'-4"
			11-7/8"	31'-0"	31'-0"	29'-2"	29'-2"	26'-11"	25'-4"
			14"	34'-3"	34'-3"	32'-2"	31'-9"	28'-1"	25'-4"

Roof Span Tables: Low Pitch (6:12 or less) for 40, 50 and 60 psf Load

TO USE:

1. Select the appropriate set of tables based on roof pitch.
2. Select the section of that table that corresponds to the specified roof live or snow load.
3. Find a span that meets or exceeds the design span for the appropriate specified roof dead load (15 psf or 20 psf).
4. Read the corresponding series, depth and spacing.

DESIGN ASSUMPTIONS:

1. The spans listed are the horizontal clear distance between supports and are valid for simple or continuous span applications. Continuous spans are based on the longest span. The shortest span shall not be less than 50% of the longest span.
2. The spans are based on uniform gravity loads only as listed for each table, including the effects of a 300 lb concentrated load. These spans have not been evaluated for wind.
3. These tables do not reflect any additional stiffness provided by the roof sheathing.
4. Live load deflection is limited to L/360.
5. Total load deflection is limited to L/180.
6. The spans are based on an end bearing length of at least 1-3/4" and an interior bearing length of at least 3-1/2", and are limited to the bearing capacity for an SPF wall plate.

ADDITIONAL NOTES:

1. Web stiffeners are not required for the Roof Span tables except when using a "bird's mouth" detail for the low-end bearing.
2. Web fillers are required for I-joists seated in hangers that do not laterally support the top flange or for hangers that require nailing into the web.
3. L/360 represents the maximum deflection allowed per code for roof joists supporting plaster or gypsum ceilings. Verify deflection limits with local code requirements.
4. Roof joists must have a minimum pitch of 1/4" per foot (1/4:12) for positive drainage.
5. Roof applications in high wind areas require special analysis which may reduce spans and may require bracing of the bottom flange and special connectors to resist uplift.
6. For conditions not shown, use the Uniform Roof Load (PLF) tables, LP's design software or contact your LP® SolidStart® Engineered Wood Products distributor for assistance.

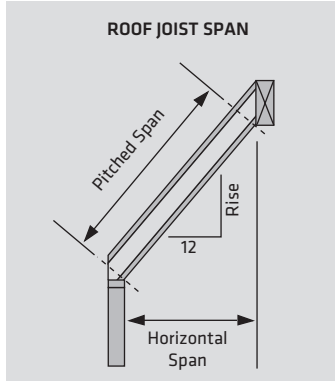

ACTUAL DEFLECTION BASED ON SPAN AND LIMIT			
Span (ft)	L/360	L/240	L/180
10'	5/16"	1/2"	11/16"
12'	3/8"	5/8"	13/16"
14'	7/16"	11/16"	15/16"
16'	9/16"	13/16"	1-1/16"
18'	5/8"	7/8"	1-3/16"
20'	11/16"	1"	1-5/16"
22'	3/4"	1-1/8"	1-7/16"
24'	13/16"	1-3/16"	1-5/8"
26'	7/8"	1-5/16"	1-3/4"
28'	15/16"	1-3/8"	1-7/8"
30'	1"	1-1/2"	2"

SPECIFIED ROOF LIVE OR SNOW LOAD (STANDARD DURATION)	Series	Depth	16" oc		19.2" oc		24" oc			
			Specified Dead Load →		15 psf	20 psf	15 psf	20 psf	15 psf	20 psf
					15 psf	20 psf	15 psf	20 psf	15 psf	20 psf
40 psf Snow	LPI 18	9'-1/2"	14'-9"	14'-9"	13'-10"	13'-10"	12'-9"	12'-9"		
		11'-7/8"	17'-10"	17'-2"	16'-4"	15'-8"	14'-7"	14'-0"		
		14"	20'-5"	20'-4"	19'-1"	18'-6"	17'-1"	15'-9"		
	LPI 20Plus	9'-1/2"	16'-1"	16'-1"	15'-1"	15'-1"	13'-11"	13'-11"		
		11'-7/8"	19'-4"	19'-4"	18'-1"	18'-1"	16'-9"	16'-7"		
		14"	22'-1"	22'-1"	20'-9"	20'-2"	18'-9"	17'-6"		
	LPI 32Plus	9'-1/2"	17'-1"	17'-1"	16'-0"	16'-0"	14'-9"	14'-9"		
		11'-7/8"	20'-5"	20'-5"	19'-1"	19'-1"	17'-8"	17'-0"		
		14"	23'-2"	23'-2"	21'-9"	21'-9"	19'-1"	17'-6"		
	LPI 36	9'-1/2"	17'-1"	17'-1"	16'-0"	16'-0"	14'-9"	14'-9"		
		11'-7/8"	20'-5"	20'-5"	19'-1"	19'-1"	17'-8"	17'-0"		
		14"	23'-2"	23'-2"	21'-9"	21'-9"	19'-1"	17'-6"		
	LPI 42Plus	9'-1/2"	19'-4"	19'-4"	18'-2"	18'-2"	16'-9"	16'-9"		
		11'-7/8"	23'-2"	23'-2"	21'-9"	21'-9"	20'-1"	20'-1"		
		14"	26'-4"	26'-4"	24'-9"	24'-9"	22'-10"	22'-10"		
	LPI 52Plus	9'-1/2"	19'-4"	19'-4"	18'-2"	18'-2"	16'-9"	16'-9"		
		11'-7/8"	23'-2"	23'-2"	21'-9"	21'-9"	20'-1"	20'-1"		
		14"	26'-4"	26'-4"	24'-9"	24'-9"	22'-10"	22'-10"		
LPI 56	9'-1/2"	27'-3"	27'-3"	25'-7"	25'-7"	23'-8"	23'-8"			
	11'-7/8"	30'-2"	30'-2"	28'-4"	28'-4"	26'-2"	25'-9"			
	14"	33'-0"	33'-0"	31'-0"	31'-0"	28'-10"	28'-10"			
50 psf Snow	LPI 18	9'-1/2"	13'-7"	13'-7"	12'-9"	12'-9"	11'-9"	11'-9"		
		11'-7/8"	16'-5"	15'-10"	15'-0"	14'-6"	13'-5"	12'-11"		
		14"	18'-10"	18'-9"	17'-8"	16'-10"	14'-5"	13'-5"		
	LPI 20Plus	9'-1/2"	14'-10"	14'-10"	13'-11"	13'-11"	12'-10"	12'-10"		
		11'-7/8"	17'-10"	17'-10"	16'-9"	16'-9"	15'-4"	14'-5"		
		14"	20'-5"	20'-5"	19'-2"	18'-7"	16'-0"	14'-11"		
	LPI 32Plus	9'-1/2"	15'-9"	15'-9"	14'-9"	14'-9"	13'-7"	13'-6"		
		11'-7/8"	18'-10"	18'-10"	17'-8"	17'-8"	15'-4"	14'-5"		
		14"	21'-5"	21'-5"	20'-1"	18'-9"	16'-0"	14'-11"		
	LPI 36	9'-1/2"	15'-9"	15'-9"	14'-9"	14'-9"	13'-7"	13'-6"		
		11'-7/8"	18'-10"	18'-10"	17'-8"	17'-8"	15'-4"	14'-5"		
		14"	21'-5"	21'-5"	20'-1"	18'-9"	16'-0"	14'-11"		
	LPI 42Plus	9'-1/2"	17'-11"	17'-11"	16'-9"	16'-9"	15'-6"	15'-6"		
		11'-7/8"	21'-5"	21'-5"	20'-1"	20'-1"	18'-6"	18'-6"		
		14"	24'-4"	24'-4"	22'-10"	22'-10"	20'-10"	19'-6"		
	LPI 52Plus	9'-1/2"	17'-11"	17'-11"	16'-9"	16'-9"	15'-6"	15'-6"		
		11'-7/8"	21'-5"	21'-5"	20'-1"	20'-1"	18'-6"	18'-6"		
		14"	24'-4"	24'-4"	22'-10"	22'-10"	20'-10"	19'-6"		
LPI 56	9'-1/2"	22'-11"	22'-11"	21'-6"	21'-6"	19'-1"	17'-10"			
	11'-7/8"	27'-1"	27'-1"	25'-4"	25'-4"	22'-6"	20'-2"			
	14"	27'-11"	27'-11"	26'-2"	26'-2"	22'-11"	21'-5"			
60 psf Snow	LPI 18	9'-1/2"	12'-9"	12'-9"	12'-0"	12'-0"	11'-0"	10'-6"		
		11'-7/8"	15'-3"	14'-10"	13'-11"	13'-6"	11'-10"	11'-2"		
		14"	17'-8"	17'-6"	15'-7"	14'-8"	12'-5"	11'-8"		
	LPI 20Plus	9'-1/2"	13'-11"	13'-11"	13'-1"	13'-1"	12'-0"	11'-9"		
		11'-7/8"	16'-9"	16'-9"	15'-8"	15'-8"	13'-2"	12'-6"		
		14"	19'-2"	19'-1"	17'-4"	16'-4"	13'-10"	13'-0"		
	LPI 32Plus	9'-1/2"	14'-9"	14'-9"	13'-10"	13'-10"	12'-5"	11'-9"		
		11'-7/8"	17'-8"	17'-8"	16'-6"	15'-8"	13'-2"	12'-6"		
		14"	20'-1"	19'-8"	17'-4"	16'-4"	13'-10"	13'-0"		
	LPI 36	9'-1/2"	14'-9"	14'-9"	13'-10"	13'-10"	12'-5"	11'-9"		
		11'-7/8"	17'-8"	17'-8"	16'-6"	15'-8"	13'-2"	12'-6"		
		14"	20'-1"	19'-8"	17'-4"	16'-4"	13'-10"	13'-0"		
	LPI 42Plus	9'-1/2"	16'-9"	16'-9"	15'-8"	15'-8"	14'-6"	14'-5"		
		11'-7/8"	20'-1"	20'-1"	18'-10"	18'-10"	17'-3"	16'-3"		
		14"	22'-10"	22'-10"	21'-5"	21'-3"	17'-11"	16'-11"		
	LPI 52Plus	9'-1/2"	16'-9"	16'-9"	15'-8"	15'-8"	14'-6"	14'-5"		
		11'-7/8"	20'-1"	20'-1"	18'-10"	18'-10"	17'-3"	16'-3"		
		14"	22'-10"	22'-10"	21'-5"	21'-3"	17'-11"	16'-11"		
LPI 56	9'-1/2"	20'-10"	20'-10"	19'-6"	19'-6"	18'-0"	18'-0"			
	11'-7/8"	25'-4"	25'-4"	23'-2"	23'-2"	19'-8"	18'-7"			
	14"	26'-2"	26'-2"	24'-7"	23'-4"	19'-8"	18'-7"			

* Deflections rounded to the nearest 1/16"

Roof Span Tables: High Pitch (6:12 to 12:12) for 20, 25 and 30 psf Load

TO USE:

1. Select the appropriate set of tables based on roof pitch.
2. Select the section of that table that corresponds to the specified roof live or snow load.
3. Find a span that meets or exceeds the design span for the appropriate specified roof dead load (15 psf or 20 psf).
4. Read the corresponding series, depth and spacing.

DESIGN ASSUMPTIONS:

1. The spans listed are the horizontal clear distance between supports and are valid for simple or continuous span applications. Continuous spans are based on the longest span. The shortest span shall not be less than 50% of the longest span.
2. The spans are based on uniform gravity loads only as listed for each table, including the effects of a 300 lb concentrated load. These spans have not been evaluated for wind.
3. These tables do not reflect any additional stiffness provided by the roof sheathing.
4. Live load deflection is limited to L/360.
5. Total load deflection is limited to L/180.
6. The spans are based on an end bearing length of at least 1-3/4" and an interior bearing length of at least 3-1/2", and are limited to the bearing capacity for an SPF wall plate.

ADDITIONAL NOTES:

1. Web stiffeners are not required for the Roof Span tables except when using a "bird's mouth" detail for the low-end bearing.
2. Web fillers are required for I-joists seated in hangers that do not laterally support the top flange or for hangers that require nailing into the web.
3. L/360 represents the maximum deflection allowed per code for roof joists supporting plaster or gypsum ceilings. Verify deflection limits with local code requirements.
4. Roof joists must have a minimum pitch of 1/4" per foot (1/4:12) for positive drainage.
5. Roof applications in high wind areas require special analysis which may reduce spans and may require bracing of the bottom flange and special connectors to resist uplift.
6. For conditions not shown, use the Uniform Roof Load (PLF) tables, LP's design software or contact your LP® SolidStart® Engineered Wood Products distributor for assistance.

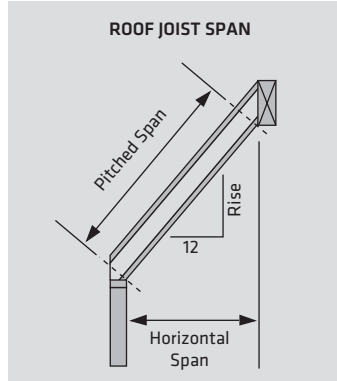

ACTUAL DEFLECTION BASED ON SPAN AND LIMIT

Span (ft)	L/360	L/240	L/180
10'	5/16"	1/2"	11/16"
12'	3/8"	5/8"	13/16"
14'	7/16"	11/16"	15/16"
16'	9/16"	13/16"	1-1/16"
18'	5/8"	7/8"	1-3/16"
20'	11/16"	1"	1-5/16"
22'	3/4"	1-1/8"	1-7/16"
24'	13/16"	1-3/16"	1-5/8"
26'	7/8"	1-5/16"	1-3/4"
28'	15/16"	1-3/8"	1-7/8"
30'	1"	1-1/2"	2"

* Deflections rounded to the nearest 1/16"

SPECIFIED ROOF LIVE OR SNOW LOAD (STANDARD DURATION)	20 psf Roof Live or Snow	Series	Depth	16" oc		19.2" oc		24" oc							
		Specified Dead Load →			15 psf	20 psf	15 psf	20 psf	15 psf	20 psf					
		LPI 18	9'-1/2"	11'-7/8"	14"	17'-3"	20'-10"	23'-10"	16'-2"	19'-6"	22'-5"	15'-4"	18'-7"	20'-9"	15'-0"
LPI 20Plus	9'-1/2"	11'-7/8"	14"	18'-10"	22'-7"	25'-10"	17'-8"	21'-3"	24'-3"	27'-9"	16'-9"	19'-8"	22'-7"	20'-2"	
	LPI 32Plus	9'-1/2"	11'-7/8"	14"	20'-0"	23'-10"	27'-2"	18'-11"	22'-7"	25'-8"	17'-9"	20'-9"	23'-7"	21'-11"	
		LPI 36	11'-7/8"	14"	16"	25'-0"	28'-4"	31'-3"	23'-8"	26'-10"	29'-7"	22'-3"	24'-7"	27'-10"	20'-7"
LPI 42Plus			9'-1/2"	11'-7/8"	14"	22'-8"	27'-1"	30'-10"	21'-5"	25'-8"	28'-11"	20'-2"	23'-7"	26'-10"	18'-8"
	LPI 52Plus		11'-7/8"	14"	16"	31'-9"	35'-2"	38'-6"	26'-4"	29'-10"	33'-1"	24'-11"	27'-8"	30'-5"	23'-1"
		LPI 56	11'-7/8"	14"	16"	29'-0"	32'-10"	36'-3"	27'-5"	30'-10"	34'-1"	25'-9"	28'-7"	31'-6"	23'-10"
25 psf Snow			LPI 18	9'-1/2"	11'-7/8"	14"	16'-2"	19'-6"	22'-4"	15'-9"	18'-8"	21'-10"	14'-10"	17'-1"	19'-5"
	LPI 20Plus			9'-1/2"	11'-7/8"	14"	17'-7"	21'-2"	24'-2"	17'-3"	20'-8"	23'-8"	16'-2"	18'-5"	21'-0"
		LPI 32Plus		9'-1/2"	11'-7/8"	14"	18'-8"	22'-4"	25'-5"	18'-3"	21'-10"	24'-10"	17'-2"	19'-5"	22'-1"
LPI 36			11'-7/8"	14"	16"	23'-4"	26'-6"	29'-3"	22'-10"	25'-11"	28'-7"	21'-6"	24'-4"	27'-10"	19'-11"
	LPI 42Plus		9'-1/2"	11'-7/8"	14"	21'-2"	25'-4"	28'-10"	19'-11"	23'-10"	27'-1"	18'-5"	21'-1"	24'-6"	18'-0"
		LPI 52Plus	11'-7/8"	14"	16"	26'-2"	29'-9"	32'-11"	24'-7"	27'-11"	30'-11"	22'-10"	25'-4"	28'-0"	22'-4"
LPI 56			11'-7/8"	14"	16"	27'-1"	30'-9"	33'-11"	26'-6"	29'-1"	31'-10"	23'-7"	26'-9"	29'-0"	23'-1"
	30 psf Snow		LPI 18	9'-1/2"	11'-7/8"	14"	15'-2"	18'-3"	20'-11"	15'-2"	18'-0"	19'-8"	14'-3"	16'-5"	18'-2"
		LPI 20Plus		9'-1/2"	11'-7/8"	14"	16'-7"	19'-10"	22'-9"	15'-6"	18'-8"	21'-4"	14'-5"	17'-3"	19'-9"
LPI 32Plus				9'-1/2"	11'-7/8"	14"	17'-7"	21'-0"	23'-10"	16'-6"	19'-8"	22'-5"	15'-3"	18'-3"	21'-9"
	LPI 36		11'-7/8"	14"	16"	24'-10"	27'-6"	30'-11"	19'-11"	23'-10"	26'-5"	18'-8"	21'-7"	24'-9"	18'-3"
		LPI 42Plus	9'-1/2"	11'-7/8"	14"	19'-11"	23'-10"	27'-1"	15'-6"	18'-8"	21'-4"	14'-5"	17'-3"	19'-9"	14'-5"
LPI 52Plus			11'-7/8"	14"	16"	26'-5"	29'-9"	32'-11"	22'-4"	25'-11"	28'-7"	17'-4"	20'-8"	23'-7"	17'-4"
	LPI 56		11'-7/8"	14"	16"	27'-1"	30'-1"	33'-2"	26'-6"	29'-1"	31'-10"	23'-7"	26'-2"	29'-0"	23'-1"
		20 psf Roof Live or Snow	LPI 18	9'-1/2"	11'-7/8"	14"	17'-3"	20'-10"	23'-10"	16'-2"	19'-6"	22'-5"	15'-4"	18'-7"	20'-9"
LPI 20Plus				9'-1/2"	11'-7/8"	14"	18'-10"	22'-7"	25'-10"	17'-8"	21'-3"	24'-3"	27'-9"	16'-9"	19'-8"
	LPI 32Plus			9'-1/2"	11'-7/8"	14"	20'-0"	23'-10"	27'-2"	18'-11"	22'-7"	25'-8"	17'-9"	20'-9"	23'-7"
		LPI 36	11'-7/8"	14"	16"	25'-0"	28'-4"	31'-3"	23'-8"	26'-10"	29'-7"	22'-3"	24'-7"	27'-10"	
LPI 42Plus			9'-1/2"	11'-7/8"	14"	22'-8"	27'-1"	30'-10"	21'-5"	25'-8"	28'-11"	20'-2"	23'-7"	26'-10"	
	LPI 52Plus		11'-7/8"	14"	16"	31'-9"	35'-2"	38'-6"	26'-4"	29'-10"	33'-1"	24'-11"	27'-8"	30'-5"	
		LPI 56	11'-7/8"	14"	16"	29'-0"	32'-10"	36'-3"	27'-5"	30'-10"	34'-1"	25'-9"	28'-7"	31'-6"	
30 psf Snow			LPI 18	9'-1/2"	11'-7/8"	14"	15'-2"	18'-3"	20'-11"	15'-2"	18'-0"	19'-8"	14'-3"	16'-5"	18'-2"
	LPI 20Plus			9'-1/2"	11'-7/8"	14"	16'-7"	19'-10"	22'-9"	15'-6"	18'-8"	21'-4"	14'-5"	17'-3"	19'-9"
		LPI 32Plus		9'-1/2"	11'-7/8"	14"	17'-7"	21'-0"	23'-10"	16'-6"	19'-8"	22'-5"	15'-3"	18'-3"	21'-9"
LPI 36			11'-7/8"	14"	16"	24'-10"	27'-6"	30'-11"	19'-11"	23'-10"	26'-5"	18'-8"	21'-7"	24'-9"	
	LPI 42Plus		9'-1/2"	11'-7/8"	14"	19'-11"	23'-10"	27'-1"	15'-6"	18'-8"	21'-4"	14'-5"	17'-3"	19'-9"	
		LPI 52Plus	11'-7/8"	14"	16"	26'-5"	29'-9"	32'-11"	22'-4"	25'-11"	28'-7"	17'-4"	20'-8"	23'-7"	
LPI 56			11'-7/8"	14"	16"	27'-1"	30'-1"	33'-2"	26'-6"	29'-1"	31'-10"	23'-7"	26'-2"	29'-0"	
	20 psf Roof Live or Snow		LPI 18	9'-1/2"	11'-7/8"	14"	17'-3"	20'-10"	23'-10"	16'-2"	19'-6"	22'-5"	15'-4"	18'-7"	20'-9"
		LPI 20Plus		9'-1/2"	11'-7/8"	14"	18'-10"	22'-7"	25'-10"	17'-8"	21'-3"	24'-3"	27'-9"	16'-9"	19'-8"
LPI 32Plus				9'-1/2"	11'-7/8"	14"	20'-0"	23'-10"	27'-2"	18'-11"	22'-7"	25'-8"	17'-9"	20'-9"	23'-7"
	LPI 36		11'-7/8"	14"	16"	25'-0"	28'-4"	31'-3"	23'-8"	26'-10"	29'-7"	22'-3"	24'-7"	27'-10"	
		LPI 42Plus	9'-1/2"	11'-7/8"	14"	22'-8"	27'-1"	30'-10"	21'-5"	25'-8"	28'-11"	20'-2"	23'-7"	26'-10"	
LPI 52Plus			11'-7/8"	14"	16"	31'-9"	35'-2"	38'-6"	26'-4"	29'-10"	33'-1"	24'-11"	27'-8"	30'-5"	
	LPI 56		11'-7/8"	14"	16"	29'-0"	32'-10"	36'-3"	27'-5"	30'-10"	34'-1"	25'-9"	28'-7"	31'-6"	
		25 psf Snow	LPI 18	9'-1/2"	11'-7/8"	14"	16'-2"	19'-6"	22'-4"	15'-9"	18'-8"	21'-10"	14'-10"	17'-1"	19'-5"
LPI 20Plus				9'-1/2"	11'-7/8"	14"	17'-7"	21'-2"	24'-2"	17'-3"	20'-8"	23'-8"	16'-2"	18'-5"	21'-0"
	LPI 32Plus			9'-1/2"	11'-7/8"	14"	18'-8"	22'-4"	25'-5"	18'-3"	21'-10"	24'-10"	17'-2"	19'-5"	22'-1"
		LPI 36	11'-7/8"	14"	16"	23'-4"	26'-6"	29'-3"	22'-10"	25'-11"	28'-7"	21'-6"	24'-4"	27'-10"	
LPI 42Plus			9'-1/2"	11'-7/8"	14"	21'-2"	25'-4"	28'-10"	19'-11"	23'-10"	27'-1"	18'-5"	21'-1"	24'-6"	
	LPI 52Plus		11'-7/8"	14"	16"	26'-2"	29'-9"	32'-11"	24'-7"	27'-11"	30'-11"	22'-10"	25'-4"	28'-0"	
		LPI 56	11'-7/8"	14"	16"	27'-1"	30'-9"	33'-11"	26'-6"	29'-1"	31'-10"	23'-7"	26'-9"	29'-0"	
30 psf Snow			LPI 18	9'-1/2"	11'-7/8"	14"	15'-2"	18'-3"	20'-11"	15'-2"	18'-0"	19'-8"	14'-3"	16'-5"	18'-2"
	LPI 20Plus			9'-1/2"	11'-7/8"	14"	16'-7"	19'-10"	22'-9"	15'-6"	18'-8"	21'-4"	14'-5"	17'-3"	19'-9"
		LPI 32Plus		9'-1/2"	11'-7/8"	14"	17'-7"	21'-0"	23'-10"	16'-6"	19'-8"	22'-5"	15'-3"	18'-3"	21'-9"
LPI 36			11'-7/8"	14"	16"	24'-10"	27'-6"	30'-11"	19'-11"	23'-10"	26'-5"	18'-8"	21'-7"	24'-9"	
	LPI 42Plus		9'-1/2"	11'-7/8"	14"	19'-11"	23'-10"	27'-1"	15'-6"	18'-8"	21'-4"	14'-5"	17'-3"	19'-9"	
		LPI 52Plus	11'-7/8"	14"	16"	26'-5"	29'-9"	32'-11"	22'-4"	25'-11"	28'-7"	17'-4"	20'-8"	23'-7"	
LPI 56			11'-7/8"	14"	16"	27'-1"	30'-1"	33'-2"	26'-6"	29'-1"	31'-10"	23'-7"	26'-2"	29'-0"	
	20 psf Roof Live or Snow		LPI 18	9'-1/2"	11'-7/8"	14"	17'-3"	20'-10"	23'-10"	16'-2"	19'-6"	22'-5"	15'-4"	18'-7"	20'-9"
		LPI 20Plus		9'-1/2"	11'-7/8"	14"	18'-10"	22'-7"	25'-10"	17'-8"	21'-3"	24'-3"	27'-9"	16'-9"	19'-8"
LPI 32Plus				9'-1/2"	11'-7/8"	14"	20'-0"	23'-10"	27'-2"	18'-11"	22'-7"	25'-8"	17'-9"	20'-9"	23'-7"
	LPI 36		11'-7/8"	14"	16"	25'-0"	28'-4"	31'-3"	23'-8"	26'-10"	29'-7"	22'-3"	24'-7"	27'-10"	
		LPI 42Plus	9'-1/2"	11'-7/8"	14"	22'-8"	27'-1"	30'-10"	21'-5"	25'-8"	28'-11"	20'-2"	23'-7"	26'-10"	
LPI 52Plus			11'-7/8"	14"	16"	31'-9"	35'-2"	38'-6"	26'-4"	29'-10"	33'-1"	24'-11"	27'-8"	30'-5"	
	LPI 56		11'-7/8"	14"	16"	29'-0"	32'-10"	36'-3"	27'-5"	30'-10"	34'-1"	25'-9"	28'-7"	31'-6"	
		25 psf Snow	LPI 18	9'-1/2"	11'-7/8"	14"	16'-2"	19'-6"	22'-4"	15'-9"	18'-8"	21'-10"	14'-10"	17'-1"	19'-5"
LPI 20Plus				9'-1/2"	11'-7/8"	14"	17'-7"	21'-2"	24'-2"	17'-3"	20'-8"	23'-8"	16'-2"	18'-5"	21'-0"
	LPI 32Plus			9'-1/2"	11'-7/8"	14"	18'-8"	22'-4"	25'-5"	18'-3"	21'-10"	24'-10"	17'-2"	19'-5"	22'-1"
		LPI 36	11'-7/8"	14"	16"	23'-4"	26'-6"	29'-3"	22'-10"	25'-11"	28'-7"	21'-6"	24'-4"	27'-10"	
LPI 42Plus			9'-1/2"	11'-7/8"	14"	21'-2"	25'-4"	28'-10"	19'-11"	23'-10"	27'-1"	18'-5"	21'-1"	24'-6"	
	LPI 52Plus		11'-7/8"	14"	16"	26'-2"	29'-9"	32'-11"	24'-7"	27'-11"	30'-11"	22'-10"	25'-4"	28'-0"	
		LPI 56	11'-7/8"	14"	16"	27'-1"	30'-9"	33'-11"	26'-6"	29'-1"	31'-10"	23'-7"	26'-9"	29'-0"	
30 psf Snow			LPI 18	9'-1/2"	11'-7/8"	14"	15'-2"</								

Roof Span Tables: High Pitch (6:12 to 12:12) for 40, 50 and 60 psf Load

TO USE:

1. Select the appropriate set of tables based on roof pitch.
2. Select the section of that table that corresponds to the specified roof live or snow load.
3. Find a span that meets or exceeds the design span for the appropriate specified roof dead load (15 psf or 20 psf).
4. Read the corresponding series, depth and spacing.

DESIGN ASSUMPTIONS:

1. The spans listed are the horizontal clear distance between supports and are valid for simple or continuous span applications. Continuous spans are based on the longest span. The shortest span shall not be less than 50% of the longest span.
2. The spans are based on uniform gravity loads only as listed for each table, including the effects of a 300 lb concentrated load. These spans have not been evaluated for wind.
3. These tables do not reflect any additional stiffness provided by the roof sheathing.
4. Live load deflection is limited to L/360.
5. Total load deflection is limited to L/180.
6. The spans are based on an end bearing length of at least 1-3/4" and an interior bearing length of at least 3-1/2", and are limited to the bearing capacity for an SPF wall plate.

ADDITIONAL NOTES:

1. Web stiffeners are not required for the Roof Span tables except when using a "bird's mouth" detail for the low-end bearing.
2. Web fillers are required for I-joists seated in hangers that do not laterally support the top flange or for hangers that require nailing into the web.
3. L/360 represents the maximum deflection allowed per code for roof joists supporting plaster or gypsum ceilings. Verify deflection limits with local code requirements.
4. Roof joists must have a minimum pitch of 1/4" per foot (1/4:12) for positive drainage.
5. Roof applications in high wind areas require special analysis which may reduce spans and may require bracing of the bottom flange and special connectors to resist uplift.
6. For conditions not shown, use the Uniform Roof Load (PLF) tables, LP's design software or contact your LP® SolidStart® Engineered Wood Products distributor for assistance.

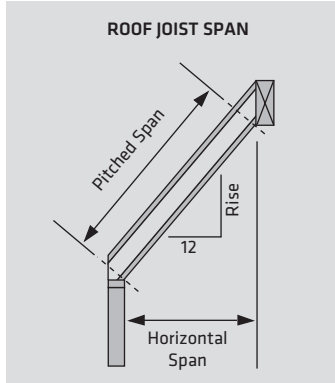

ACTUAL DEFLECTION BASED ON SPAN AND LIMIT

Span (ft)	L/360	L/240	L/180
10'	5/16"	1/2"	11/16"
12'	3/8"	5/8"	13/16"
14'	7/16"	11/16"	15/16"
16'	9/16"	13/16"	1-1/16"
18'	5/8"	7/8"	1-3/16"
20'	11/16"	1"	1-5/16"
22'	3/4"	1-1/8"	1-7/16"
24'	13/16"	1-3/16"	1-5/8"
26'	7/8"	1-5/16"	1-3/4"
28'	15/16"	1-3/8"	1-7/8"
30'	1"	1-1/2"	2"

* Deflections rounded to the nearest 1/16"

SPECIFIED ROOF LIVE OR SNOW LOAD (STANDARD DURATION)	Series	Depth	16" oc		19.2" oc		24" oc			
			Specified Dead Load →		15 psf	20 psf	15 psf	20 psf	15 psf	20 psf
			15 psf	20 psf	15 psf	20 psf	15 psf	20 psf		
40 psf Snow	LPI 18	9'-1/2"	13'-9"	13'-9"	12'-11"	12'-11"	11'-11"	11'-11"		
		11'-7/8"	16'-7"	16'-6"	15'-7"	15'-1"	14'-2"	13'-6"		
		14"	19'-0"	19'-0"	17'-10"	17'-10"	16'-0"	14'-6"		
	LPI 20Plus	9'-1/2"	15'-0"	15'-0"	14'-1"	14'-1"	13'-0"	13'-0"		
		11'-7/8"	18'-0"	18'-0"	16'-11"	16'-11"	15'-7"	15'-7"		
		14"	20'-7"	20'-7"	19'-4"	19'-4"	17'-10"	16'-2"		
	LPI 32Plus	9'-1/2"	15'-11"	15'-11"	14'-11"	14'-11"	13'-9"	13'-9"		
		11'-7/8"	19'-0"	19'-0"	17'-10"	17'-10"	16'-6"	16'-1"		
		14"	21'-7"	21'-7"	20'-3"	20'-3"	17'-10"	16'-2"		
	LPI 36	9'-1/2"	19'-10"	19'-10"	18'-8"	18'-8"	17'-3"	17'-2"		
		11'-7/8"	22'-6"	22'-6"	21'-2"	21'-2"	19'-0"	17'-3"		
		14"	24'-11"	24'-11"	23'-4"	23'-4"	19'-1"	17'-3"		
	LPI 42Plus	9'-1/2"	18'-0"	18'-0"	16'-11"	16'-11"	15'-8"	15'-8"		
		11'-7/8"	21'-7"	21'-7"	20'-3"	20'-3"	18'-9"	18'-9"		
		14"	24'-6"	24'-6"	23'-0"	23'-0"	21'-4"	21'-4"		
	LPI 52Plus	9'-1/2"	27'-3"	27'-3"	25'-7"	25'-7"	23'-8"	22'-6"		
		11'-7/8"	22'-4"	22'-4"	20'-11"	20'-11"	19'-5"	19'-5"		
		14"	25'-4"	25'-4"	23'-9"	23'-9"	22'-0"	22'-0"		
LPI 56	9'-1/2"	28'-0"	28'-0"	26'-4"	26'-4"	24'-4"	23'-11"			
	11'-7/8"	23'-1"	23'-1"	21'-8"	21'-8"	20'-0"	19'-4"			
	14"	26'-2"	26'-2"	24'-6"	24'-3"	21'-4"	19'-4"			
50 psf Snow	LPI 18	9'-1/2"	12'-8"	12'-8"	11'-11"	11'-11"	11'-0"	11'-0"		
		11'-7/8"	15'-4"	15'-4"	14'-5"	14'-0"	13'-1"	12'-5"		
		14"	17'-7"	17'-7"	16'-6"	15'-9"	13'-8"	12'-6"		
	LPI 20Plus	9'-1/2"	13'-10"	13'-10"	13'-0"	13'-0"	12'-0"	12'-0"		
		11'-7/8"	16'-8"	16'-8"	15'-7"	15'-7"	14'-5"	13'-11"		
		14"	19'-0"	19'-0"	17'-10"	17'-6"	15'-2"	13'-11"		
	LPI 32Plus	9'-1/2"	21'-2"	21'-1"	19'-1"	19'-1"	17'-7"	14'-0"		
		11'-7/8"	14'-8"	14'-8"	13'-9"	13'-9"	12'-9"	12'-9"		
		14"	17'-7"	17'-7"	16'-6"	16'-6"	15'-1"	13'-11"		
	LPI 36	9'-1/2"	20'-0"	20'-0"	18'-9"	17'-6"	15'-2"	13'-11"		
		11'-7/8"	18'-5"	18'-5"	17'-3"	17'-3"	15'-11"	14'-10"		
		14"	20'-10"	20'-10"	19'-7"	18'-8"	16'-2"	14'-10"		
	LPI 42Plus	9'-1/2"	22'-1"	21'-1"	19'-1"	17'-7"	15'-3"	14'-0"		
		11'-7/8"	23'-0"	22'-6"	20'-4"	18'-8"	16'-3"	14'-11"		
		14"	25'-2"	25'-2"	23'-8"	23'-8"	21'-1"	19'-5"		
	LPI 52Plus	9'-1/2"	16'-8"	16'-8"	15'-8"	15'-8"	14'-5"	14'-5"		
		11'-7/8"	19'-11"	19'-11"	18'-9"	18'-9"	17'-4"	17'-4"		
		14"	22'-8"	22'-8"	21'-4"	21'-4"	19'-8"	18'-9"		
LPI 56	9'-1/2"	25'-2"	25'-2"	23'-8"	23'-8"	21'-1"	19'-5"			
	11'-7/8"	20'-8"	20'-8"	19'-5"	19'-5"	17'-11"	17'-11"			
	14"	23'-5"	23'-5"	22'-0"	22'-0"	20'-4"	20'-3"			
60 psf Snow	LPI 18	9'-1/2"	11'-11"	11'-11"	11'-2"	11'-2"	10'-4"	10'-4"		
		11'-7/8"	14'-5"	14'-5"	13'-6"	13'-2"	11'-9"	10'-11"		
		14"	16'-6"	16'-6"	14'-10"	13'-10"	11'-10"	11'-0"		
	LPI 20Plus	9'-1/2"	13'-0"	13'-0"	12'-2"	12'-2"	11'-3"	11'-3"		
		11'-7/8"	15'-7"	15'-7"	14'-8"	14'-8"	13'-2"	12'-2"		
		14"	17'-10"	17'-10"	16'-7"	15'-5"	13'-2"	12'-3"		
	LPI 32Plus	9'-1/2"	19'-11"	18'-7"	16'-7"	15'-5"	13'-3"	12'-4"		
		11'-7/8"	13'-9"	13'-9"	12'-11"	12'-11"	11'-11"	11'-11"		
		14"	18'-9"	18'-6"	16'-7"	15'-5"	13'-2"	12'-3"		
	LPI 36	9'-1/2"	20'-0"	18'-7"	16'-7"	15'-5"	13'-3"	12'-4"		
		11'-7/8"	17'-3"	17'-3"	16'-2"	16'-2"	14'-0"	13'-0"		
		14"	19'-7"	19'-7"	17'-8"	16'-4"	14'-1"	13'-1"		
	LPI 42Plus	9'-1/2"	21'-3"	19'-9"	17'-8"	16'-5"	14'-1"	13'-1"		
		11'-7/8"	15'-8"	15'-8"	14'-8"	14'-8"	13'-7"	13'-7"		
		14"	18'-9"	18'-9"	17'-7"	17'-7"	16'-3"	15'-10"		
	LPI 52Plus	9'-1/2"	21'-4"	21'-4"	20'-0"	20'-0"	17'-9"	16'-6"		
		11'-7/8"	23'-8"	23'-8"	22'-2"	21'-5"	18'-4"	17'-1"		
		14"	23'-8"	23'-8"	22'-2"	21'-5"	18'-4"	17'-1"		
LPI 56	9'-1/2"	19'-5"	19'-5"	18'-2"	18'-2"	16'-10"	16'-10"			
	11'-7/8"	22'-0"	22'-0"	20'-8"	20'-8"	19'-1"	17'-9"			
	14"	24'-4"	24'-4"	22'-11"	22'-9"	19'-6"	18'-1"			
LPI 56	9'-1/2"	20'-0"	20'-0"	18'-9"	18'-4"	15'-9"	14'-7"			
	11'-7/8"	22'-8"	22'-1"	19'-10"	18'-5"	15'-9"	14'-8"			
	14"	23'-10"	22'-2"	19'-10"	18'-5"	15'-10"	14'-8"			

C1 NO REINFORCEMENT REQUIRED

Min. APA Rated 23/32" OSB (or equal) closure, or as required by code

* LP® SolidStart® Rim Board, LVL or LSL may be substituted for the LPI Blocking

C1W WEB STIFFENER REQUIRED

Min. APA Rated 23/32" OSB (or equal) closure, or as required by code

* LP SolidStart Rim Board, LVL or LSL may be substituted for the LPI Blocking

C2 23/32" OSB (OR EQUAL) REINFORCEMENT ONE SIDE ONLY

Min. APA Rated 23/32" OSB (or equal) closure, or as required by code

* LP® SolidStart® Rim Board, LVL or LSL may be substituted for the LPI Blocking

C3 23/32" OSB (OR EQUAL) REINFORCEMENT BOTH SIDES

Min. APA Rated 23/32" OSB (or equal) closure, or as required by code

* LP SolidStart Rim Board, LVL or LSL may be substituted for the LPI Blocking

C7 BRICK LEDGE CANTILEVER WEB FILLER REINFORCING

Web fillers both sides (refer to table below for size)

Use construction adhesive between surfaces

Blocking panels are required at the bearing, but are not shown for clarity

C8 BRICK LEDGE CANTILEVER FULL-DEPTH REINFORCING

For 14" and 16" I-joists, web filler (both sides) and OSB or plywood reinforcing are required (see detail C7)

Construction adhesive is recommended between surfaces

Reinforcing shall be same depth as I-joist

Blocking panels are required at the bearing, but are not shown for clarity

* NOTE: Pilot holes required when using screws

Brick-Ledge Cantilevers

TOTAL JOIST REACTION CALCULATION

LP® SolidStart® I-joists can cantilever up to 6" to support a load-bearing wall over a brick finish. Depending on the Total Joist Reaction (TJR), the joists may require reinforcement. If the TJR is less than the End Reaction Capacity W/out Stiffeners (page 4), then no reinforcement is required. If the TJR is greater than the End Reaction Capacity W/out Stiffeners, but less than the End Reaction Capacity With Stiffeners, then web stiffeners shall be installed at the bearing. Otherwise, one of the reinforcing details from below shall be used.

TOTAL JOIST REACTION, TJR = FLR + WLR + RLR

Where: **FLR** = Floor Load Reaction

WLR = Wall Load Reaction

RLR = Roof Load Reaction, including any other floor, ceiling or attic loads imposed on wall

C7 Web filler reinforcing

C8 Full depth reinforcing

LP SolidStart Rim Board closure

LP SolidStart I-Joist or Rim Board full-depth blocking

6" max

Alternate Flat Blocking:
Use 9-1/2" LP SolidStart Rim Board or 2 x 10 (SPF min).
Blocking shall cover wall plate and extend to end of cantilever.
Nail rim board to blocking and blocking to wall plate with 8d common nails at 6" oc or as required for floor panel edge nailing.

Series	Minimum Web Filler	Factored Reaction Resistance (lbs)
LPI 18	23/32" APA Rated OSB (or equal)	3230
LPI 20Plus LPI 32Plus LPI 36	23/32" APA Rated OSB (or equal)	3660
LPI 42Plus LPI 52Plus LPI 56	1-1/8" APA Rated OSB (or equal)	5630

Series	Factored Reaction Resistance (lbs)	
	23/32" APA Rated OSB (or equal)	1" Min. LP SolidStart Rim Board
LPI 18	4360	4780
LPI 20Plus LPI 32Plus LPI 36	4930	5350
LPI 42Plus LPI 52Plus LPI 56	6760	7320

EXAMPLE 1:

I-Joist: 9-1/2" LPI 20Plus Wall under Cantilever: 3-1/2" wide

Specified
Design Loads: Floor: 40/10 psf **Floor System:** Joist Span = 16' **Roof System:** Roof Span = 22'
 Roof: 20/10 psf Joist Cantilever = 5" Roof Overhang = 1'
 Wall: 80 plf Joist Spacing = 16" oc

Factored FLR = (Joist Span / 2 + Joist Cantilever / 12) * (Factored Floor Load) * (Joist Spacing / 12)
 = (16' / 2 + 5" / 12) * (1.5 * 40 psf + 1.25 * 10 psf) * (16" / 12)
 = 814 lbs.

Factored WLR = (Factored Wall Load) * (Joist Spacing / 12)
 = (1.25 * 80 plf) * (16" / 12)
 = 133 lbs.

Factored RLR = (Roof Span / 2 + Roof Overhang) * (Factored Roof Load) * (Joist Spacing / 12)
 = (22' / 2 + 1') * (1.5 * 20 psf + 1.25 * 10 psf) * (16" / 12)
 = 680 lbs.

Factored TJR = 814 + 133 + 680
 = 1627 lbs.

FACTORED END REACTION RESISTANCE			
9-1/2" LPI 20Plus on a 3-1/2" wall	Min. 1-1/2" Bearing	Max. 4" Bearing	3-1/2" Bearing
w/o Web Stiffeners	1530	1750	1706
w/Web Stiffeners	1800	1990	1952
w/Web Filler Reinforcing	-	-	3660
w/ 23/32" APA Rated OSB Full-Depth Reinforcing (One Side)	-	-	4930
w/ 1" LP Rim Full-Depth Reinforcing (One Side)	-	-	5350

Since the Factored Total Joist Reaction, 1627 lbs., is less than the Factored End Reaction Resistance w/out Stiffeners for 3-1/2" bearing (1706 lbs.), no reinforcement is required.

EXAMPLE 2:

I-Joist: 11-7/8" LPI 32Plus Wall under Cantilever: 3-1/2" wide

Specified
Design Loads: Floor: 40/15 psf **Floor System:** Joist Span = 16' **Roof System:** Roof Span = 32'
 Roof: 30/15 psf Joist Cantilever = 5" Roof Overhang = 1'
 Wall: 100 plf Joist Spacing = 24" oc

Factored FLR = (Joist Span / 2 + Joist Cantilever / 12) * (Factored Floor Load) * (Joist Spacing / 12)
 = (16' / 2 + 5" / 12) * (1.5 * 40 psf + 1.5 * 15 psf) * (24" / 12)
 = 1326 lbs.

Factored WLR = (Factored Wall Load) * (Joist Spacing / 12)
 = (1.25 * 100 plf) * (24" / 12)
 = 250 lbs.

Factored RLR = (Roof Span / 2 + Roof Overhang) * (Factored Roof Load) * (Joist Spacing / 12)
 = (32' / 2 + 1') * (1.5 * 30 psf + 1.25 * 15 psf) * (24" / 12)
 = 2168 lbs.

Factored TJR = 1326 + 250 + 2168
 = 3744 lbs.

FACTORED END REACTION RESISTANCE			
11-7/8" LPI 32Plus on a 3-1/2" wall	Min. 1-1/2" Bearing	Max. 4" Bearing	3-1/2" Bearing
w/o Web Stiffeners	1530	1830	1770
w/Web Stiffeners	2010	2345	2278
w/Web Filler Reinforcing	-	-	3660
w/ 23/32" APA Rated OSB Full-Depth Reinforcing (One Side)	-	-	4930
w/ 1" LP Rim Full-Depth Reinforcing (One Side)	-	-	5350

Since the Factored Total Joist Reaction, 3744 lbs., is greater than the Factored End Reaction Resistance with Web Filler Reinforcing (3660 lbs.), but is less than the Factored End Reaction Resistance with 23/32" APA Rated OSB Full-Depth Reinforcing (4930 lbs.), this joist requires the installation of full-depth reinforcing consisting of a minimum 23/32" APA Rated OSB (or equal) attached to one side (Detail C8) at the bearing.

Web Hole Specifications: Circular Holes

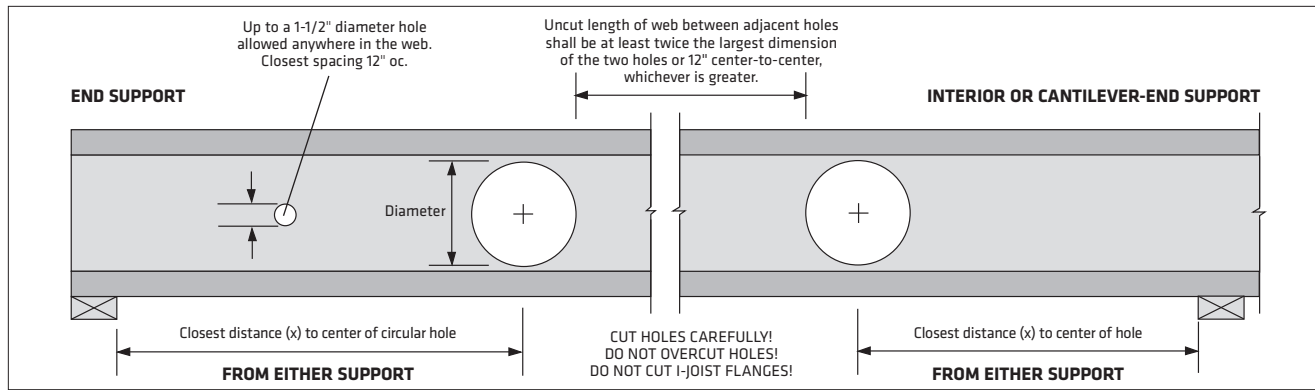

TO USE:

1. Select the required series and depth.
2. Determine the support condition for the nearest bearing: end support or interior support (including cantilever-end supports).
3. Select the row corresponding to the required Clear Span. For spans between those listed, use the next largest value.
4. Select the column corresponding to the required hole diameter. For diameters between those listed, use the next largest value.
5. The intersection of the Clear Span row and Hole Diameter column gives the minimum distance from the inside face of bearing to the center of a circular hole.
6. Double check the distance to the other support, using the appropriate support condition.

Series	Depth	Clear Span (ft)	Distance from End Support				Distance from Interior or Cantilever-End Support							
			Hole Diameter				Hole Diameter							
			2"	4"	6"	8"	10"	12"	2"	4"	6"	8"	10"	12"
LPI 18	9-1/2"	6'	1'-0"	1'-0"	1'-0"	-	-	-	1'-0"	1'-0"	1'-0"	-	-	
		10'	1'-0"	1'-0"	2'-1"	-	-	-	1'-0"	1'-3"	3'-1"	-	-	
		14'	1'-0"	2'-2"	4'-6"	-	-	-	1'-11"	3'-9"	5'-7"	-	-	
		18'	2'-4"	4'-7"	7'-2"	-	-	-	4'-5"	6'-3"	8'-4"	-	-	
	11-7/8"	10'	1'-0"	1'-0"	1'-0"	1'-10"	-	-	1'-0"	1'-0"	1'-3"	3'-0"	-	-
		14'	1'-0"	1'-0"	2'-1"	4'-4"	-	-	1'-0"	2'-0"	3'-9"	5'-6"	-	-
		18'	1'-0"	2'-5"	4'-6"	6'-11"	-	-	2'-9"	4'-6"	6'-3"	8'-1"	-	-
		22'	2'-8"	4'-9"	7'-0"	9'-8"	-	-	5'-3"	7'-0"	8'-9"	11'-0"	-	-
	14"	14'	1'-0"	1'-0"	1'-0"	2'-3"	4'-5"	-	1'-0"	1'-0"	2'-2"	3'-10"	5'-6"	-
		18'	1'-0"	1'-0"	2'-7"	4'-8"	7'-0"	-	1'-4"	3'-0"	4'-8"	6'-4"	8'-2"	-
		22'	1'-1"	2'-11"	4'-11"	7'-2"	9'-9"	-	3'-10"	5'-6"	7'-2"	8'-10"	-	-
		26'	3'-3"	5'-3"	7'-5"	9'-9"	12'-6"	-	6'-4"	8'-0"	9'-8"	11'-6"	-	-
LPI 20Plus & LPI 32Plus	9-1/2"	6'	1'-0"	1'-0"	1'-0"	-	-	-	1'-0"	1'-0"	1'-0"	-	-	
		10'	1'-0"	1'-0"	1'-0"	-	-	-	1'-0"	1'-0"	1'-0"	-	-	
		14'	1'-0"	1'-0"	1'-5"	-	-	-	1'-0"	1'-5"	3'-1"	-	-	
		18'	1'-0"	1'-9"	3'-8"	-	-	-	2'-3"	3'-11"	5'-7"	-	-	
	11-7/8"	10'	1'-0"	1'-0"	1'-0"	1'-0"	-	-	1'-0"	1'-0"	1'-0"	1'-0"	-	-
		14'	1'-0"	1'-0"	1'-0"	1'-9"	-	-	1'-0"	1'-0"	2'-1"	3'-5"	-	-
		18'	1'-0"	1'-0"	2'-6"	4'-1"	-	-	1'-10"	3'-3"	4'-7"	5'-11"	-	-
		22'	1'-8"	3'-2"	4'-10"	6'-7"	-	-	4'-4"	5'-9"	7'-1"	8'-5"	-	-
	14"	14'	1'-0"	1'-0"	1'-0"	1'-0"	2'-2"	-	1'-0"	1'-0"	1'-5"	2'-7"	3'-9"	-
		18'	1'-0"	1'-0"	1'-9"	3'-1"	4'-6"	-	1'-8"	2'-10"	3'-11"	5'-1"	6'-3"	-
		22'	1'-5"	2'-9"	4'-1"	5'-6"	7'-2"	-	4'-2"	5'-4"	6'-5"	7'-7"	8'-9"	-
		26'	3'-8"	5'-0"	6'-5"	8'-0"	9'-8"	-	6'-8"	7'-10"	8'-11"	10'-1"	11'-4"	-
16"	18'	1'-1"	1'-0"	1'-4"	2'-5"	3'-7"	4'-11"	1'-6"	2'-6"	3'-6"	4'-6"	5'-6"	6'-6"	
	22'	1'-4"	2'-5"	3'-6"	4'-9"	6'-1"	7'-5"	4'-0"	5'-0"	6'-0"	7'-0"	8'-0"	9'-0"	
	26'	3'-6"	4'-8"	5'-11"	7'-2"	8'-7"	10'-1"	6'-6"	7'-6"	8'-6"	9'-6"	10'-6"	11'-9"	
	30'	5'-9"	7'-0"	8'-4"	9'-9"	11'-3"	12'-10"	9'-0"	10'-0"	11'-0"	12'-0"	13'-2"	14'-8"	
LPI 36 & LPI 56	11-7/8"	10'	1'-0"	1'-0"	1'-0"	1'-0"	-	-	1'-0"	1'-0"	1'-0"	1'-3"	-	
		14'	1'-0"	1'-0"	1'-0"	2'-2"	-	-	1'-0"	1'-0"	1'-8"	3'-9"	-	
		18'	1'-0"	1'-0"	2'-0"	4'-7"	-	-	1'-0"	2'-1"	4'-2"	6'-3"	-	
		22'	1'-0"	1'-11"	4'-4"	7'-1"	-	-	2'-6"	4'-7"	6'-8"	8'-9"	-	
	14"	14'	1'-0"	1'-0"	1'-0"	1'-0"	2'-10"	-	1'-0"	1'-0"	1'-0"	2'-6"	4'-4"	-
		18'	1'-0"	1'-0"	1'-0"	3'-0"	5'-3"	-	1'-0"	1'-5"	3'-3"	5'-0"	6'-10"	-
		22'	1'-0"	1'-3"	3'-2"	5'-4"	7'-10"	-	2'-2"	3'-11"	5'-9"	7'-6"	9'-4"	-
		26'	1'-5"	3'-5"	5'-6"	7'-10"	10'-6"	-	4'-8"	6'-5"	8'-3"	10'-0"	12'-2"	-
	16"	18'	1'-0"	1'-0"	1'-0"	2'-0"	3'-10"	5'-11"	1'-0"	1'-0"	2'-7"	4'-1"	5'-8"	7'-3"
		22'	1'-0"	1'-0"	2'-5"	4'-3"	6'-3"	8'-6"	1'-11"	3'-6"	5'-1"	6'-7"	8'-2"	9'-11"
		26'	1'-3"	2'-11"	4'-8"	6'-8"	8'-10"	11'-3"	4'-5"	6'-0"	7'-7"	9'-1"	10'-8"	12'-10"
		30'	3'-4"	5'-2"	7'-1"	9'-2"	11'-5"	14'-0"	6'-11"	8'-6"	10'-1"	11'-7"	13'-5"	-
LPI 42Plus & LPI 52Plus	9-1/2"	6'	1'-0"	1'-0"	1'-0"	-	-	-	1'-0"	1'-0"	1'-0"	-	-	
		10'	1'-0"	1'-0"	1'-0"	-	-	-	1'-0"	1'-0"	1'-0"	-	-	
		14'	1'-0"	1'-0"	1'-5"	-	-	-	1'-0"	1'-5"	3'-1"	-	-	
		18'	1'-0"	1'-9"	3'-8"	-	-	-	2'-3"	3'-11"	5'-7"	-	-	
	11-7/8"	10'	1'-0"	1'-0"	1'-0"	1'-0"	-	-	1'-0"	1'-0"	1'-0"	1'-0"	-	-
		14'	1'-0"	1'-0"	1'-0"	1'-9"	-	-	1'-0"	1'-0"	2'-1"	3'-5"	-	-
		18'	1'-0"	1'-0"	2'-6"	4'-1"	-	-	1'-10"	3'-3"	4'-7"	5'-11"	-	-
		22'	1'-8"	3'-2"	4'-10"	6'-7"	-	-	4'-4"	5'-9"	7'-1"	8'-5"	-	-
	14"	14'	1'-0"	1'-0"	1'-0"	1'-0"	2'-2"	-	1'-0"	1'-0"	1'-5"	2'-7"	3'-9"	-
		18'	1'-0"	1'-0"	1'-9"	3'-1"	4'-6"	-	1'-8"	2'-10"	3'-11"	5'-1"	6'-3"	-
		22'	1'-5"	2'-9"	4'-1"	5'-6"	7'-0"	-	4'-2"	5'-4"	6'-5"	7'-7"	8'-9"	-
		26'	3'-8"	5'-0"	6'-5"	8'-0"	9'-8"	-	6'-8"	7'-10"	8'-11"	10'-1"	11'-4"	-
16"	18'	1'-0"	1'-0"	1'-4"	2'-5"	3'-7"	4'-11"	1'-6"	2'-6"	3'-6"	4'-6"	5'-6"	6'-6"	
	22'	1'-4"	2'-5"	3'-6"	4'-9"	6'-1"	7'-5"	4'-0"	5'-0"	6'-0"	7'-0"	8'-0"	9'-0"	
	26'	3'-6"	4'-8"	5'-11"	7'-2"	8'-7"	10'-1"	6'-6"	7'-6"	8'-6"	9'-6"	10'-6"	11'-9"	
	30'	5'-9"	7'-0"	8'-4"	9'-9"	11'-3"	12'-10"	9'-0"	10'-0"	11'-0"	12'-0"	13'-2"	14'-8"	

DESIGN ASSUMPTIONS:

1. The hole locations listed above are valid for floor joists supporting only uniform loads. The total uniform load shall not exceed 130 plf (e.g., 40 psf Live Load and 25 psf Dead Load spaced 24" oc).
2. Hole location is measured from the inside face of bearing to the center of a circular hole, from the closest support.
3. Clear Span has not been verified for these joists and is shown for informational purposes only! Verify that the joist selected will work for the span and loading conditions needed before checking hole location.
4. The maximum hole depth for circular holes is the I-Joist Depth less 4," except the maximum hole depth is 6" for 9-1/2" LPI joists, and 8" for 11-7/8" LPI joists.
5. Holes cannot be located in the span where designated "-", without further analysis by a design professional.

NOTES:

1. Holes may be placed anywhere within the depth of the joist. A minimum 1/4" clear distance is required between the hole and the flanges.
2. Round holes up to 1-1/2" diameter may be placed anywhere in the web.
3. Perforated "knockouts" may be neglected when locating web holes.
4. Holes larger than 1-1/2" are not permitted in cantilevers without special engineering.
5. Multiple holes shall have a clear separation along the length of the joist of at least twice the larger dimension of the larger adjacent hole, or a minimum of 12" center-to-center, whichever is greater.
6. Multiple holes may be spaced closer provided they fit within the boundary of an acceptable larger hole. Example: two 3" round holes aligned parallel to the joist length may be spaced 2" apart (clear distance) provided that a 3" high by 8" long rectangle or an 8" diameter round hole are acceptable for the joist depth at that location and completely encompass the holes.
7. For conditions not covered in this table, use LP's design software or contact your local LP® SolidStart® Engineered Wood Products distributor for more information.

Web Hole Specifications: Rectangular Holes

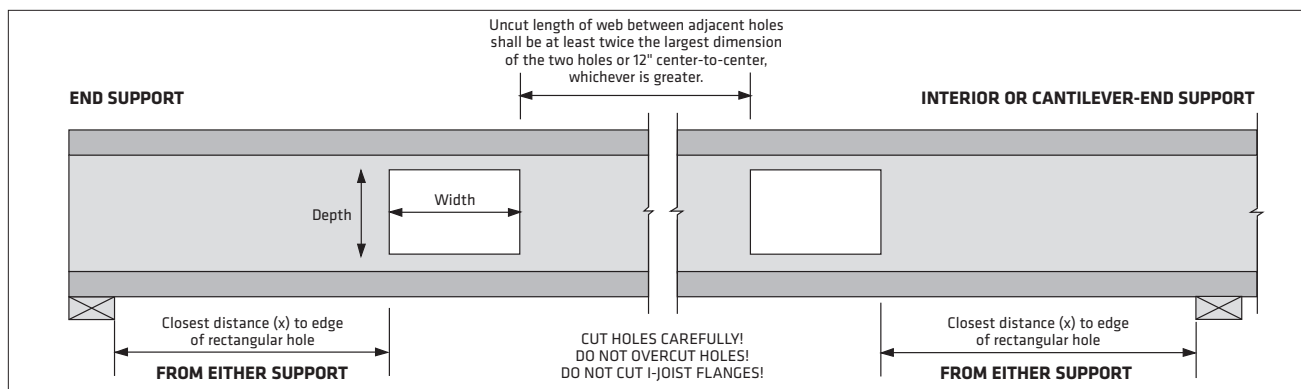

TO USE:

- 1 Select the required series and depth.
- 2 Determine the support condition for the nearest bearing: end support or interior support (including cantilever-end supports).
- 3 Select the row corresponding to the required Clear Span. For spans between those listed, use the next largest value.
- 4 Select the column corresponding to the required hole dimension. For dimensions between those listed, use the next largest value.
- 5 The intersection of the Clear Span row and Hole Dimension column gives the minimum distance from the inside face of bearing to the nearest edge of a square or rectangular hole.
- 6 Double check the distance to the other support, using the appropriate support condition.

Series	Depth	Clear Span (ft)	Distance from End Support						Distance from Interior or Cantilever-End Support						
			Maximum Hole Dimension: Depth or Width						Maximum Hole Dimension: Depth or Width						
			2"	4"	6"	8"	10"	12"	2"	4"	6"	8"	10"	12"	
LPI 18	9-1/2"	6'	1'-0"	1'-0"	1'-0"	1'-0"	1'-0"	1'-2"	1'-7"	1'-0"	1'-3"	1'-3"	1'-6"	1'-10"	2'-2"
		10'	1'-0"	1'-4"	2'-10"	3'-3"	3'-9"	4'-3"	1'-3"	2'-6"	3'-9"	4'-0"	4'-5"	-	-
		14'	2'-2"	3'-8"	5'-5"	5'-11"	6'-6"	-	3'-9"	5'-0"	6'-4"	-	-	-	-
		18'	4'-7"	6'-3"	8'-2"	-	-	-	6'-3"	7'-6"	-	-	-	-	-
	11-7/8"	10'	1'-0"	1'-0"	2'-2"	3'-6"	4'-0"	-	1'-1"	2'-2"	3'-2"	4'-2"	-	-	-
		14'	2'-0"	3'-3"	4'-8"	6'-3"	-	-	3'-7"	4'-8"	5'-8"	-	-	-	-
		18'	4'-4"	5'-9"	7'-3"	-	-	-	6'-1"	7'-2"	8'-5"	-	-	-	-
		22'	6'-10"	8'-4"	10'-1"	-	-	-	8'-7"	9'-9"	-	-	-	-	-
	14"	14'	1'-0"	1'-0"	1'-4"	3'-2"	5'-4"	6'-1"	1'-0"	1'-6"	3'-1"	4'-7"	6'-3"	-	-
		18'	1'-0"	1'-10"	3'-8"	5'-8"	8'-1"	-	2'-5"	4'-0"	5'-7"	7'-1"	-	-	-
		22'	2'-4"	4'-1"	6'-1"	8'-3"	-	-	4'-11"	6'-6"	8'-1"	9'-9"	-	-	-
		26'	4'-7"	6'-6"	8'-7"	11'-0"	-	-	7'-5"	9'-0"	10'-7"	12'-7"	-	-	-
LPI 20Plus & LPI 32Plus	9-1/2"	6'	1'-0"	1'-0"	1'-0"	1'-0"	1'-5"	1'-0"	1'-0"	1'-0"	1'-3"	1'-8"	2'-0"	-	
		10'	1'-0"	1'-0"	2'-6"	2'-11"	3'-5"	3'-11"	1'-0"	2'-1"	3'-5"	3'-9"	4'-2"	-	
		14'	1'-7"	3'-2"	5'-0"	5'-7"	6'-1"	-	3'-3"	4'-7"	5'-11"	6'-5"	-	-	
		18'	3'-11"	5'-8"	7'-9"	8'-4"	-	-	5'-9"	7'-1"	-	-	-	-	
	11-7/8"	10'	1'-0"	1'-9"	3'-3"	3'-9"	4'-3"	1'-0"	1'-9"	2'-10"	4'-0"	4'-5"	-	-	
		14'	1'-5"	2'-9"	4'-2"	5'-11"	6'-6"	-	3'-1"	4'-3"	5'-4"	-	-	-	
		18'	3'-8"	5'-2"	6'-9"	8'-8"	-	-	5'-7"	6'-9"	7'-11"	-	-	-	
		22'	6'-1"	7'-9"	9'-6"	-	-	-	8'-1"	9'-3"	-	-	-	-	
	14"	14'	1'-0"	1'-0"	1'-0"	2'-8"	4'-11"	5'-9"	1'-0"	1'-0"	2'-6"	4'-2"	5'-10"	-	
		18'	1'-0"	1'-0"	2'-11"	5'-1"	7'-7"	8'-6"	1'-7"	3'-3"	5'-0"	6'-8"	-	-	
		22'	1'-4"	3'-3"	5'-4"	7'-8"	10'-5"	-	4'-1"	5'-9"	7'-6"	9'-2"	-	-	
		26'	3'-6"	5'-7"	7'-10"	10'-4"	-	-	6'-7"	8'-3"	10'-0"	12'-0"	-	-	
16"	18'	1'-0"	1'-0"	2'-5"	4'-4"	6'-5"	-	1'-5"	3'-0"	4'-6"	6'-1"	7'-8"	-		
	22'	1'-2"	2'-11"	4'-9"	6'-10"	9'-2"	-	3'-11"	5'-6"	7'-0"	8'-7"	10'-6"	-		
	26'	3'-4"	5'-2"	7'-2"	9'-5"	11'-11"	-	6'-5"	8'-0"	9'-6"	11'-1"	-	-		
	30'	5'-8"	7'-7"	9'-9"	12'-1"	-	-	8'-11"	10'-6"	12'-0"	14'-0"	-	-		
LPI 36 & LPI 56	11-7/8"	10'	1'-0"	1'-0"	1'-9"	3'-3"	3'-9"	4'-3"	1'-0"	1'-9"	2'-10"	4'-0"	4'-5"	-	
		14'	1'-5"	2'-9"	4'-2"	5'-11"	6'-6"	-	3'-1"	4'-3"	5'-4"	-	-	-	
		18'	3'-8"	5'-2"	6'-9"	8'-8"	-	-	5'-7"	6'-9"	7'-11"	-	-	-	
		22'	6'-1"	7'-9"	9'-6"	-	-	-	8'-1"	9'-3"	-	-	-	-	
	14"	14'	1'-0"	1'-0"	1'-0"	2'-8"	4'-11"	5'-9"	1'-0"	1'-0"	2'-6"	4'-2"	5'-10"	-	
		18'	1'-0"	1'-0"	2'-11"	5'-1"	7'-7"	8'-6"	1'-7"	3'-3"	5'-0"	6'-8"	-	-	
		22'	1'-4"	3'-3"	5'-4"	7'-8"	10'-5"	-	4'-1"	5'-9"	7'-6"	9'-2"	-	-	
		26'	3'-6"	5'-7"	7'-10"	10'-4"	-	-	6'-7"	8'-3"	10'-0"	12'-0"	-	-	
	16"	18'	1'-0"	1'-0"	2'-5"	4'-4"	6'-5"	-	1'-5"	3'-0"	4'-6"	6'-1"	7'-8"	-	
		22'	1'-2"	2'-11"	4'-9"	6'-10"	9'-2"	-	3'-11"	5'-6"	7'-0"	8'-7"	10'-6"	-	
		26'	3'-4"	5'-2"	7'-2"	9'-5"	11'-11"	-	6'-5"	8'-0"	9'-6"	11'-1"	-	-	
		30'	5'-8"	7'-7"	9'-9"	12'-1"	-	-	8'-11"	10'-6"	12'-0"	14'-0"	-	-	
LPI 42Plus & LPI 52Plus	9-1/2"	6'	1'-0"	1'-0"	1'-0"	1'-0"	1'-5"	1'-0"	1'-0"	1'-0"	1'-3"	1'-8"	2'-0"		
		10'	1'-0"	1'-0"	2'-6"	2'-11"	3'-5"	3'-11"	1'-0"	2'-1"	3'-5"	3'-9"	4'-2"		
		14'	1'-7"	3'-2"	5'-0"	5'-7"	6'-1"	-	3'-3"	4'-7"	5'-11"	6'-5"	-		
		18'	3'-11"	5'-8"	7'-9"	8'-4"	-	-	5'-9"	7'-1"	-	-	-		
	11-7/8"	10'	1'-0"	1'-0"	1'-9"	3'-3"	3'-9"	4'-3"	1'-0"	1'-9"	2'-10"	4'-0"	4'-5"		
		14'	1'-5"	2'-9"	4'-2"	5'-11"	6'-6"	-	3'-1"	4'-3"	5'-4"	-	-		
		18'	3'-8"	5'-2"	6'-9"	8'-8"	-	-	5'-7"	6'-9"	7'-11"	-	-		
		22'	6'-1"	7'-9"	9'-6"	-	-	-	8'-1"	9'-3"	-	-	-		
	14"	14'	1'-0"	1'-0"	1'-0"	2'-8"	4'-11"	5'-9"	1'-0"	1'-0"	2'-6"	4'-2"	5'-10"		
		18'	1'-0"	1'-0"	2'-11"	5'-1"	7'-7"	8'-6"	1'-7"	3'-3"	5'-0"	6'-8"	-		
		22'	1'-4"	3'-3"	5'-4"	7'-8"	10'-5"	-	4'-1"	5'-9"	7'-6"	9'-2"	-		
		26'	3'-6"	5'-7"	7'-10"	10'-4"	-	-	6'-7"	8'-3"	10'-0"	12'-0"	-		
16"	18'	1'-0"	1'-0"	2'-5"	4'-4"	6'-5"	-	1'-5"	3'-0"	4'-6"	6'-1"	7'-8"			
	22'	1'-2"	2'-11"	4'-9"	6'-10"	9'-2"	-	3'-11"	5'-6"	7'-0"	8'-7"	10'-6"			
	26'	3'-4"	5'-2"	7'-2"	9'-5"	11'-11"	-	6'-5"	8'-0"	9'-6"	11'-1"	-			
	30'	5'-8"	7'-7"	9'-9"	12'-1"	-	-	8'-11"	10'-6"	12'-0"	14'-0"	-			

DESIGN ASSUMPTIONS:

1. The hole locations listed above are valid for floor joists supporting only uniform loads. The total uniform load shall not exceed 130 plf (e.g., 40 psf Live Load and 25 psf Dead Load spaced 24" oc).
2. Hole location is measured from the inside face of bearing to the nearest edge of a rectangular hole, from the closest support.
3. Clear Span has not been verified for these joists and is shown for informational purposes only! Verify that the joist selected will work for the span and loading conditions needed before checking hole location.
4. The maximum hole depth for rectangular holes is the I-joist Depth less 4" except the maximum hole depth is 6" for 9-1/2" LPI joists, and 8" for 11-7/8" LPI Joists. Where the Maximum Hole Dimension exceeds the hole depth, the dimension refers to hole width and the depth of the hole is assumed to be the maximum for that joist depth. The maximum hole width is 18" regardless of I-joist Depth.
5. Holes cannot be located in the span where designated "-", without further analysis by a design professional.

NOTES:

1. Holes may be placed anywhere within the depth of the joist. A minimum 1/4" clear distance is required between the hole and the flanges.
2. Round holes up to 1-1/2" diameter may be placed anywhere in the web.
3. Perforated "knockouts" may be neglected when locating web holes.
4. Holes larger than 1-1/2" are not permitted in cantilevers without special engineering.
5. Multiple holes shall have a clear separation along the length of the joist of at least twice the larger dimension of the larger adjacent hole, or a minimum of 12" center-to-center, whichever is greater.
6. Multiple holes may be spaced closer provided they fit within the boundary of an acceptable larger hole. Example: two 3" round holes aligned parallel to the joist length may be spaced 2" apart (clear distance) provided that a 3" high by 8" long rectangle or an 8" diameter round hole are acceptable for the joist depth at that location and completely encompass the holes.
7. For conditions not covered in this table, use LP's design software or contact your local LP® SolidStart® Engineered Wood Products distributor for more information.

<p>A1 RIM BOARD</p> <p>A1W RIM BOARD Web Stiffener Required</p> <p>Fasten rim board to each floor I-joist using one 8d nail or 10d box nail per flange</p> <p>Web stiffener for Detail A1W only</p> <p>Same depth as I-joist</p> <p>8d nails at 6" oc toe-nailed from outside of building</p>	<p>A2 RIM JOIST Refer to Note 8</p> <p>Rim joists with flanges wider than 1-3/4" require a minimum 2 x 6 plate</p> <p>Fasten rim joist to each floor I-joist with one 10d nail into the end of each flange. Use 16d box nails for rim joists with flanges wider than 1-3/4"</p> <p>8d nails at 6" oc (when used for shear transfer, nail to bearing plate with same nailing schedule for decking)</p>	<p>A3 BLOCKING AT EXTERIOR WALL</p> <p>8d nails at 6" oc (when used for shear transfer, nail to bearing plate with same nailing schedule for decking)</p>
---	--	--

<p>A4 SOLID BLOCKING AT EXTERIOR WALL</p> <p>LP LVL, LP LSL or LP Rim Board as blocking</p> <p>Same depth as I-joist</p> <p>8d nails at 6" oc toe-nailed from outside of building</p>	<p>A5 JOIST SUPPORT NAILING</p> <p>Secure I-joist to plate with two 8d nails or 10d box. Drive one nail from each side of I-joist, angled inward.</p> <p>Place nail 1-1/2" min. from end of I-joist. If nails are close to edge of plate, drive at an angle to reduce splitting</p>	<p>B1 WEB STIFFENERS AT INTERIOR SUPPORT (When Required)</p> <p>Verify stiffener requirements (see Web Stiffener detail)</p>
--	--	---

<p>B2 SQUASH BLOCKS</p> <p>Blocking panels may be required with shear wall</p> <p>Use double squash blocks as specified. Squash blocks shall be cut 1/16" taller than I-joist. 2 x 4 min.</p> <p>Stagger 8d or 10d nails to avoid splitting</p> <p>Bearing wall aligned under wall above</p> <p>Toe-nail 8d or 10d box nail to plate</p>	<p>B3 BLOCKING AT INTERIOR SUPPORT</p> <p>Blocking is not required if no wall above unless I-joists end at support. Blocking may be required at interior supports by project designer or by code for seismic design</p> <p>Bearing wall aligned under wall above</p>	<p>NON-STACKING WALLS</p> <p>LP SolidStart I-joists shall be designed to carry all applied loads including walls from above that do not stack directly over the I-joist support.</p>
---	---	---

<p>D2 POST LOADS</p> <p>Squash blocks required under all post loads</p>	<p>E1 STAIR STRINGER</p> <p>Web filler (as backer block) minimum 12" long</p> <p>Filler block(s) minimum 4' long</p> <p>Approved connection (by others)</p> <p>See I-joist Header Cross-Section for connection information of the filler and backer blocks</p> <p>See I-joist Filler Schedule for filler block and web filler sizes</p>	<p>E2 HANGER DETAIL</p> <p>Verify capacity and fastening requirements of hangers and connectors</p> <p>Verify web filler requirements for hangers</p>
--	--	--

E3 I-JOIST HEADER

Verify web filler/stiffener requirements for hangers

See Double I-Joist Connection detail

Verify all hanger connections

Filler blocks

Web filler (as backer block)

Filler blocks

See I-Joist Header Cross-Section for information on attaching web fillers and filler blocks

Refer to I-Joist Filler Thickness table for web filler (backer block) and filler block sizes

E5 DOUBLE I-JOIST CONNECTION

Floor sheathing to be glued and nailed to flanges of both plies

6" oc

6" oc

Filler block

See I-Joist Header Cross-Section for information on attaching filler blocks

Refer to I-Joist Filler Thickness table for filler block sizes

E4 I-JOIST HEADER CROSS-SECTION

Web filler (as backer block)

Verify web filler/stiffener requirements for hangers

Filler block(s)

Supported hanger (top-mount shown)

NOTES:

1. Backer blocks and filler blocks shall consist of APA Rated wood structural panel (OSB or plywood), 2 x lumber (SPF or better), or LP® SolidStart® LVL, LSL or OSB Rim Board, with a net thickness equivalent to that shown in the I-Joist Filler Thickness table below.
2. Except as noted in 3, backer blocks and filler blocks shall fit the clear distance between flanges with a gap of at least 1/8," but not more than 1," and shall be of sufficient depth to allow for all hanger nailing into the web. Do not force into place.
3. Backer blocks and filler blocks for double I-joists that are top-loaded only or side-loaded supporting top-mount hangers that do not require nailing into the web, shall be at least 5-1/2" deep for I-joists to 11-7/8" deep, and shall be at least 7-1/4" deep for I-joists 14" and deeper.
4. Install backer blocks tight to top flange for top-loaded joists and for joists supporting top-mount hangers (shown). Install tight to bottom flange for joists supporting face-mount hangers.
5. Clinch nails where possible.
6. For double I-joists, additional nailing may be required to transfer point loads. For additional information, contact your LP SolidStart Engineered Wood Products distributor.

Web Filler/Backer Block: Backer blocks shall be at least 12" long and located behind every supported hanger. For a single I-joist header, install backer blocks to both sides of the web. Two pieces of 2 x 8 (min.) lumber, cut to the proper height (see notes 2 & 3), may be set vertically side-by-side to achieve the required minimum 12" length.

Attach backer blocks with 8d nails (use 10d nails for flanges wider than 2-1/2"). Use a minimum of 10 nails spaced to avoid splitting, with half the nails to each side of the center of the supported hanger.

Note: Backer blocks may be omitted for top-mount hangers supporting only factored downward loads not exceeding 360 lbs.

Filler Blocks: Install in minimum 4' long sections at each support, centered behind each supported hanger and at no more than 8' oc. Lumber fillers may be stacked to achieve the required depth (see notes 2 & 3). For example, two 4' long 2 x 8's may be stacked vertically to achieve the filler depth for an 18" deep I-joist (minimum required depth is 18" - 3" - 1" = 14").

Attach filler blocks with 8d nails (10d for flanges wider than 2-1/2") nails spaced 6" oc per row. Use one row of nails in each row of stacked fillers, with a minimum of two rows of nails. Drive every other nail from opposite sides.

NON LOAD-BEARING CANTILEVER

OSB or equal closure

Uniform loads only

1/3 adjacent span (max.)

Adjacent span

BEVEL CUT/FIRE CUT

LPI blocking or other lateral support required at ends of I-joist

Bevel cut may not extend beyond inside face of bearing wall

I-JOIST FILLER THICKNESS		
Series	Filler Block	Web Filler/Backer Block
LPI 18 LPI 20Plus LPI 32Plus	2-1/8"	1"
LPI 36	1-7/8"	7/8"
LPI 42Plus LPI 52Plus LPI 56	3"	1-1/2"

GENERAL NOTES:

1. Some wind or seismic loads may require different or additional details and connections.
2. Verify building code requirements for suitability of details shown.
3. Refer to page 4 for bearing length requirements.
4. Refer to page 5 for Flange Face Nailing Schedule for LPI rim joist or blocking panel nailing.
5. Lateral support shall be considered for bottom flange when there is no sheathing on underside.
6. Verify capacity and fastening requirements of hangers and connectors.
7. Squash block capacity designed by others.
8. Do not use LPI joists with flanges wider than 2-1/2" as rim joists.

NOTES:

1. Backer blocks and filler blocks shall consist of APA Rated wood structural panel (OSB or plywood), or 2x lumber (SPF or better).
2. LP LVL, LSL or OSB Rim Board may also be used.
3. Refer to the Notes for the I-Joist Header Cross-Section above for details on the required height and length, and nailing of the backer blocks and filler blocks.

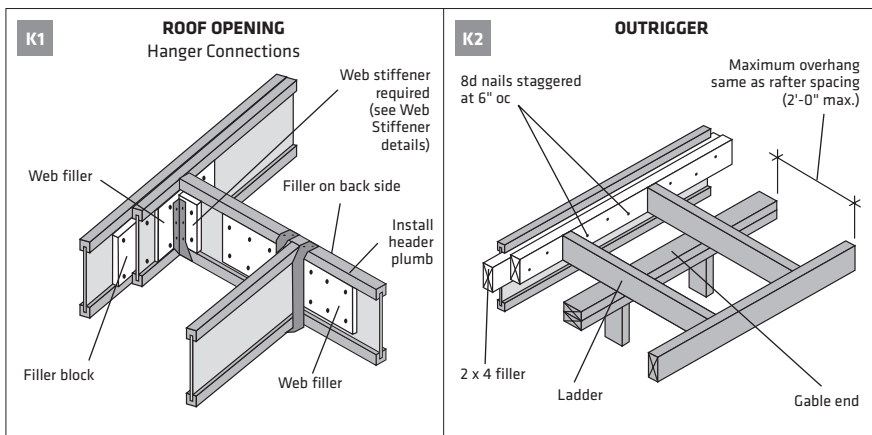
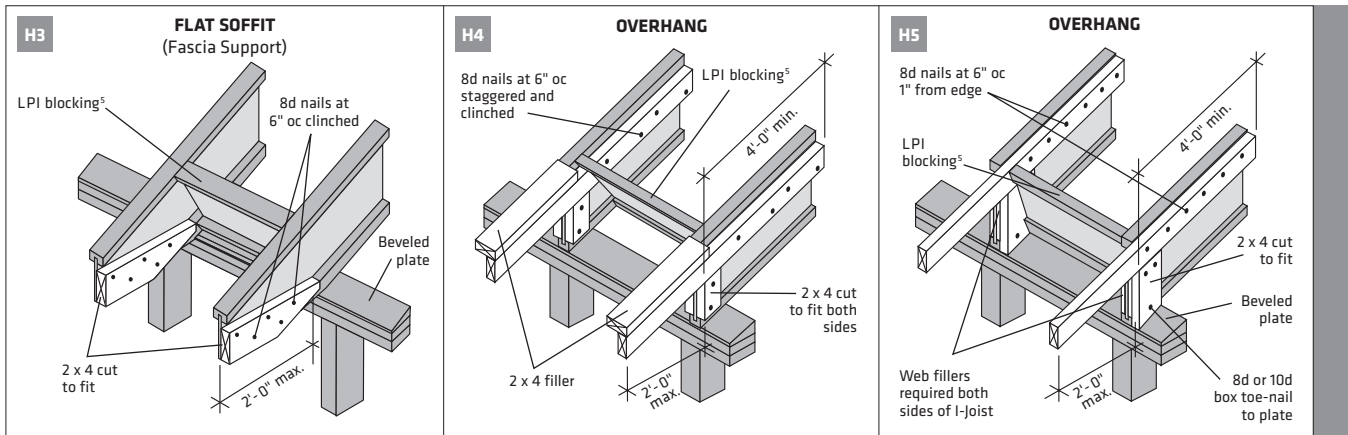
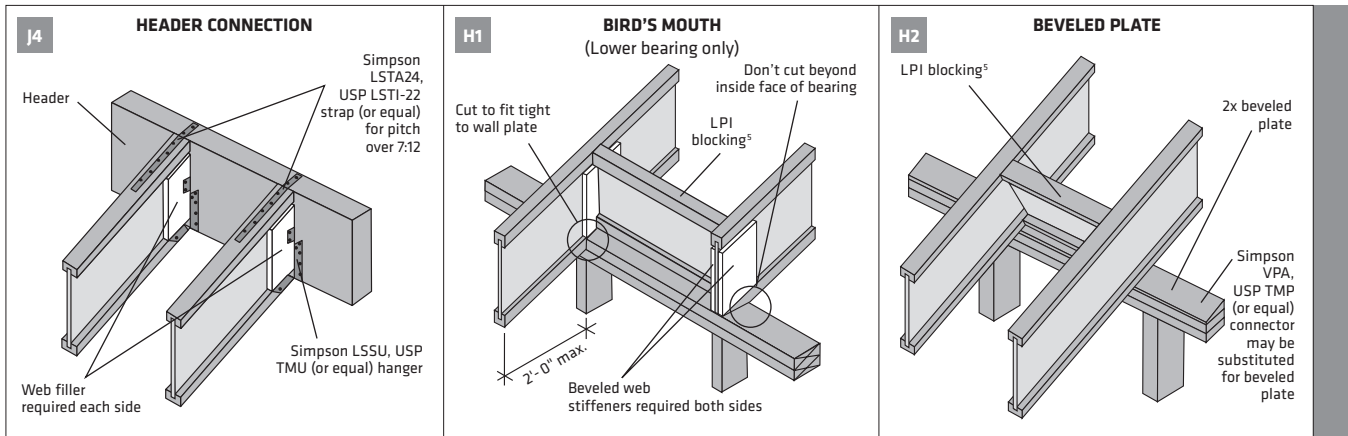
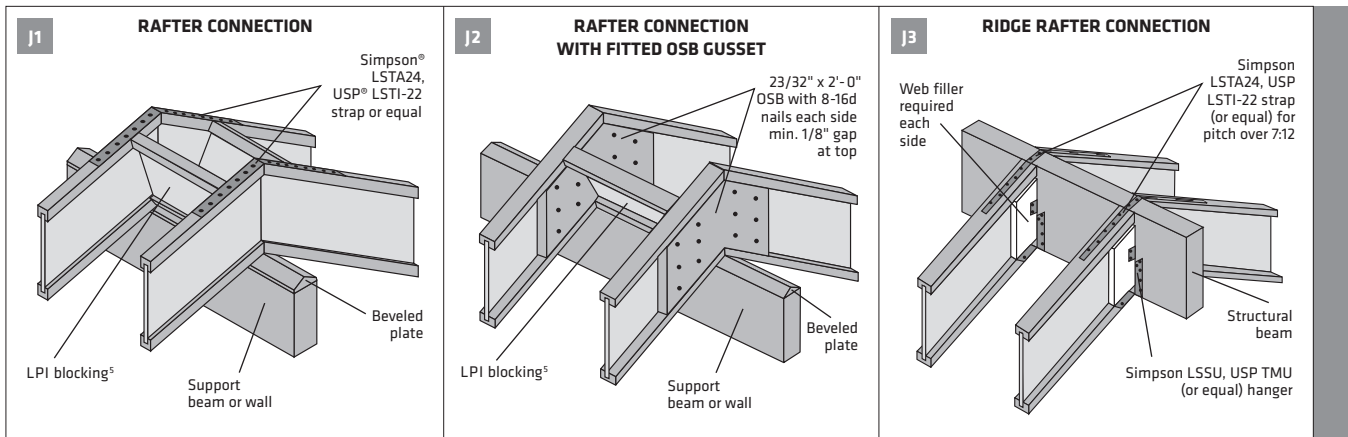

NOTES:

1. Minimum pitch: 1/4" per foot (1/4:12). Maximum pitch: 12" per foot (12:12).
2. Verify capacity and fastening requirements of hangers and connectors.
3. Some wind or seismic loads may require different or additional details and connections. Uplift anchors may be required.
4. 4" diameter hole(s) may be cut in blocking for ventilation.
5. Lateral resistance shall be provided. Other methods of restraint, such as full depth LP SolidStart OSB Rim Board, LP® SolidStart® LVL, LP SolidStart LSL or metal X-bracing may be substituted for the LP blocking shown.

GENERAL NOTES:

1. The following tables provide a list of the more common hangers and connectors for use with LP® SolidStart® I-joists.
2. Refer to the manufacturer's connector guide for a complete list of hangers and to verify the suitability of a hanger or connector for a particular application.
3. Follow all connector manufacturers' installation guidelines.

SIMPSON STRONG-TIE®								
Series	Depth	Top-Mount		Face-Mount		45° Skewed	Field Slope & Skew	Variable Pitch Seat
		Single	Double	Single	Double	Single	Single	Single
LPI 18 LPI 20Plus LPI 32Plus	9-1/2"	ITS2.56/9.5	MIT39.5-2	IUS2.56/9.5	MIU5.12/9	SUR/L2.56/9	LSSUH310 *	VPA3
	11-7/8"	ITS2.56/11.88	MIT311.88-2	IUS2.56/11.88	MIU5.12/12	SUR/L2.56/11	LSSUH310 *	VPA3
	14"	ITS2.56/14	MIT314-2	IUS2.56/14	MIU5.12/14	SUR/L2.56/14	LSSUH310 *	VPA3
	16"	ITS2.56/16	MIT5.12/16	IUS2.56/16	MIU5.12/16	SUR/L2.56/14 *	**	VPA3
LPI 36	11-7/8"	ITS2.37/11.88	MIT3511.88-2	IUS2.37/11.88	MIU4.75/11	SUR/L2.37/11	LSSUI35 *	VPA35
	14"	ITS2.37/14	MIT3514-2	IUS2.37/14	MIU4.75/14	SUR/L2.37/14	LSSUI35 *	VPA35
	16"	ITS2.37/16	MIT4.75/16	IUS2.37/16	MIU4.75/16	SUR/L2.37/14 *	**	VPA35
LPI 42Plus LPI 52Plus LPI 56	9-1/2"	ITS3.56/9.5	B7.12/9.5 *	IUS3.56/9.5	HU410-2 *	SUR/L410 *	LSSU410 *	VPA4
	11-7/8"	ITS3.56/11.88	B7.12/11.88 *	IUS3.56/11.88	HU412-2 *	SUR/L410 *	LSSU410 *	VPA4
	14"	ITS3.56/14	B7.12/14 *	IUS3.56/14	HU414-2 *	SUR/L414 *	LSSU410 *	VPA4
	16"	ITS3.56/16	B7.12/16 *	IUS3.56/16	HU414-2 *	SUR/L414 *	**	VPA4

* Web filler required for proper installation of hanger.

** Refer to Simpson Strong-Tie "Wood Construction Connectors" catalog for hanger selection.

USP STRUCTURAL CONNECTORS®								
Series	Depth	Top-Mount		Face-Mount		45° Skewed	Field Slope & Skew	Variable Pitch Seat [†]
		Single	Double	Single	Double	Single	Single	Single
LPI 18 LPI 20Plus LPI 32Plus	9-1/2"	TFL2595	THO25950-2 *	THF25925	THF25925-2 *	SKH2520L/R *	LSSH25 *	TMP25 or TMPH25 *
	11-7/8"	TFL25118	THO25118-2 *	THF25112	THF25112-2 *	SKH2520L/R *	LSSH25 *	TMP25 or TMPH25 *
	14"	TFL2514	THO25140-2 *	THF25140	THF25140-2 *	SKH2524L/R *	LSSH25 *	TMP25 or TMPH25 *
	16"	TFL2516	THO25160-2 *	THF25160	THF25160-2 *	SKH2524L/R *	LSSH25 * [†]	TMP25 or TMPH25 *
LPI 36	11-7/8"	TFL23118	THO23118-2 *	THF23118	THF23118-2 *	SKH2320L/R *	LSSH23 *	TMP23 or TMPH23 *
	14"	TFL2314	THO23140-2 *	THF23140	THF23140-2 *	SKH2324L/R *	LSSH23 *	TMP23 or TMPH23 *
	16"	TFL2316	THO23160-2 *	THF23160	THF23160-2 *	SKH2324L/R *	LSSH23 * [†]	TMP23 or TMPH23 *
LPI 42Plus LPI 52Plus LPI 56	9-1/2"	THO35950	BPH7195 *	THF35925	HD7100 *	SKH410L/R * **	LSSH35 *	TMP4 or TMPH4 *
	11-7/8"	THO35118	BPH71118 *	THF35112	HD7120 *	SKH410L/R * **	LSSH35 *	TMP4 or TMPH4 *
	14"	THO35140	BPH7114 *	THF35140	HD7140 *	SKH414L/R * **	LSSH35 *	TMP4 or TMPH4 *
	16"	THO35160	BPH7116 *	THF35157	HD7160 *	SKH414L/R * **	LSSH35 * [†]	TMP4 or TMPH4 *

* Web filler required for proper installation of hanger.

** Miter cut required on end of joist.

[†] Hanger height is less than 60% of the joist depth. Supplemental lateral support of the top flange is required. Refer to USP's installation instructions.

1. Use TMP seats for joist pitch of 1:12 to 6:12. Use TMPH for joist pitch of 6:12 and greater.

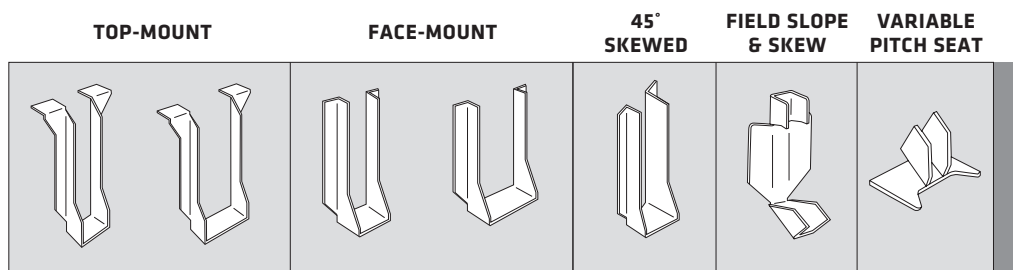

FACTORED RIM BOARD RESISTANCE

Material	Grade	Thickness	Vertical Load Resistance ¹			Lateral Load ^{4,5,6} Resistance, ϕH (plf)
			Uniform, ϕV^2 (plf)		Concentrated, ϕP^3 (lbs)	
			$d \leq 16''$	$16'' < d \leq 24''$	$d \leq 24''$	
LP OSB	APA Rated Rim Board	1-1/8"	7339	5004	5838	234
LP LSL	1730F _b -1.35E	$\geq 1-1/4''$	10008	6338	6338	326
LP LVL (cross-ply)	1750F _b -1.3E	$\geq 1-1/4''$	13970	8457	7022	326

NOTES:

- The Factored Vertical Load Resistance shall not be increased for short-term load duration.
- The Factored Vertical Load Resistance is based on the capacity of the rim board and may need to be reduced based on the bearing resistance of the supporting wall plate or the attached floor sheathing. Example: The specified bearing strength for commodity OSB floor sheathing is 609 psi (4.2 MPa) so the uniform vertical load resistance of a 1-1/4" x 16" deep rim board would be limited to 8678 plf (= 0.95 * 609 psi x 1-1/4" x 12").
- The Factored Concentrated Vertical Load Resistance is assumed to be applied through a minimum 4-1/2" bearing length (3-stud post).
- The Factored Lateral Load Resistance is based on a short-term load duration and shall not be increased.
- The Factored Lateral Load Resistance is based on the connections specified in the Installation details below.
- Additional framing connectors fastened to the face of the rim board may be used to increase lateral resistance for wind and seismic design.

FACTORED UNIFORM LOAD (PLF) RESISTANCE FOR RIM BOARD HEADERS: MAXIMUM 4' CLEAR SPAN

Material	Thickness	Rim Board Depth			
		9-1/2"	11-7/8"	2-Ply 14"	2-Ply 16"
LP OSB	1-1/8"	620 (1-1/2")	915 (3")	2410 (4-1/2")	2980 (4-1/2")
LP LSL	1-1/4"	955 (1-1/2")	1810 (3")	5155 (4-1/2")	6535 (6")
LP LVL (cross-ply)	1-1/4"	865 (1-1/2")	1645 (3")	4675 (4-1/2")	5925 (6")

NOTES:

- This table is for preliminary design for uniform gravity loads only. Final design should include a complete analysis of all loads and connections.
- The factored load resistances are for a maximum 4' clear span with minimum bearings for each end (listed in parentheses) based on the bearing resistance of the rim board. For headers bearing on wood plates, the bearing length may need to be increased based on the ratio of the bearing resistance of the rim board divided by the bearing resistance of the plate species.
- Standard load duration is assumed and shall be adjusted according to code.
- Depths greater than 11-7/8" shall be used with a minimum of two plies, as shown. Depths of 11-7/8" and less may be used as a two-ply header by multiplying the resistance by two.
- Multiple-ply headers shall be toe-nailed to the plate from both faces. Fasten the floor sheathing to the top of each ply to provide proper lateral support for each ply.
- For multiple-ply headers supporting top-loads only, fasten plies together with minimum 2-1/2" nails (common wire or spiral) at a maximum spacing of 12" oc. Use 2 rows of nails for 9-1/2" and 11-7/8". Use 3 rows for depths 14" and greater. Clinch the nails where possible. For side-loaded multiple-ply headers, refer to the Connection Resistance For Side-Loaded 2-Ply Rim Board Headers table below for the required nailing and the maximum side load that can be applied.
- The designer shall verify proper bearing for the header.
- Joints in the rim are not allowed over openings and must be located at least 12" from any opening.
- Refer to the "APA Performance Rated Rim Boards - Limit States Design" (Form No. D340 CA) for additional information including uniform load resistance for smaller openings.
- Use LP® SolidStart® LSL or LVL for headers with clear spans longer than 4' or for loads greater than tabulated above. Refer to the appropriate technical guide for LP LSL and LVL design values.

FACTORED CONNECTION RESISTANCE FOR SIDE-LOADED 2-PLY RIM BOARD HEADERS (PLF)

Material	Thickness	Minimum Nail Size	3 Rows of Nails at 6" oc	4 Rows of Nails at 6" oc	5 Rows of Nails at 6" oc	6 Rows of Nails at 6" oc
LP OSB	1" & 1-1/8"	2-1/2" x 0.113"	1368	1824	2280	2736
LP LSL and LP LVL (cross-ply)	1-1/4"	2-1/2" x 0.113"	1368	1824	2280	2736
	1-1/2" & 1-3/4"	3" x 0.120"	1524	2032	2540	3048

NOTES:

- This table represents the factored uniform side-load resistance of the connection for a 2-ply header. The total factored uniform load, including top-load and side-load, shall not exceed the factored uniform load resistance of the header as tabulated above.
- The tabulated side-load resistance is for standard load duration and shall be adjusted according to code.
- Use 3 rows of nails for 9-1/2" and 11-7/8"; 4 rows for 14" and 16"; 5 rows for 18" and 20"; 6 rows for 22" and 24" deep rim board. Clinch the nails where possible.
- The factored resistance is calculated in accordance with CSA O86-09 for the nail sizes listed.
- Headers consisting of more than 2 plies, alternate fastening or higher side loads are possible but require proper design of the connection.

INSTALLATION

RIM TO JOIST CONNECTION

Nail rim to I-joist with one 8d (box or common) or 10d box nail into each flange.

DECK TO RIM AND RIM TO PLATE CONNECTIONS¹

- Nail floor sheathing to rim board with 8d nails at 6" oc.
- Nail wall plate through floor sheathing into rim per code.
- Toe-nail rim board to wall plate with 8d nails at 6" oc.

T&G TRIM REQUIREMENTS²

See T&G Trim Requirements table below for when to trim tongue or groove.

NOTE:

- Additional framing connectors to the face of the rim board may be used to increase lateral capacity for wind and seismic design.
- Trim the tongue or groove of the floor sheathing in accordance with the T&G Trim Requirements table.

T&G TRIM REQUIREMENTS

Floor Sheathing Thickness	Rim Board Thickness			
	1"	1-1/8"	1-1/4"	> 1-1/4"
$\leq 7/8''$	Trim	Not Required	Not Required	Not Required
$> 7/8''$	Trim	Trim	Trim	Not Required

WARNINGS

The following conditions are **NOT** permitted!

Do not use visually damaged products without first checking with your local LP SolidStart Engineered Wood Products distributor or sales office.

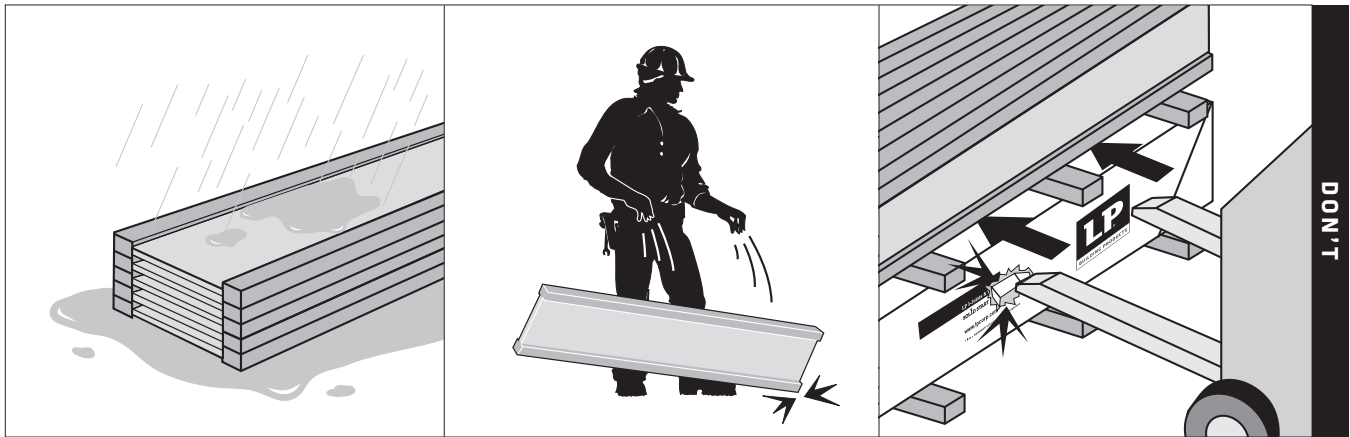

<p>DON'T put holes too close to supports.</p> <p>Refer to hole chart for correct location.</p>	<p>DON'T overcut hole and damage flange.</p>	<p>DON'T make hole with hammer unless knock-out is provided.</p> <p>DON'T hammer on flange and damage joist.</p>	<p>DON'T cut or notch flange.</p> <p>DON'T drill flange.</p>
<p>DON'T cut flange for pipes.</p>	<p>DON'T use 16d nails.</p> <p>Refer to Joist End Nailing detail for correct sizes and locations.</p>	<p>DON'T cut beyond inside edge of bearing.</p>	<p>DON'T support I-Joist on web.</p>

Handling & Storage Guidelines

Warning: Failure to follow proper procedures for handling, storage and installation could result in unsatisfactory performance, unsafe structures and possible collapse.

Keep LP® SolidStart® Engineered Wood Products dry. These products are intended to resist the effects of moisture on structural performance from normal construction delays but are not intended for permanent exposure to the weather.

Unload products carefully, by lifting. Support the bundles to reduce excessive bowing. Individual products should be handled in a manner which prevents physical damage during measuring, cutting, erection, etc. I-Joists shall be handled vertically and not flatwise.

Keep products stored in wrapped and strapped bundles, stacked no more than 10' high. Support and separate bundles with 2 x 4 (or larger) stickers spaced no more than 10' apart. Keep stickers in line vertically.

Product must not be stored in contact with the ground, or have prolonged exposure to the weather.

Use forklifts and cranes carefully to avoid damaging product.

Do not use a visually damaged product. Call your local LP SolidStart Engineered Wood Products distributor for assistance when damaged products are encountered.

For satisfactory performance, LP SolidStart I-Joists, LSL and LVL must be used under dry, covered and well-ventilated interior conditions in which the equilibrated moisture content does not exceed a yearly average of 15% and does not exceed 19% at any time.

For built-up members, LP SolidStart I-Joists, LSL and LVL shall be dry before nailing or bolting to avoid trapping moisture.

LP SolidStart I-Joists, LSL and LVL shall not be used for unintended purposes such as ramps and planks.

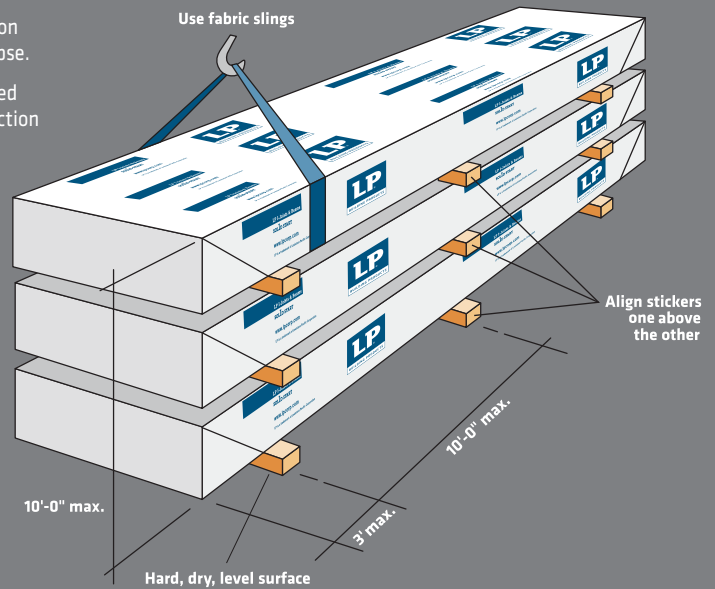

LP SolidStart I-Joists

LPI 18

Width: 2-1/2"
 Depths: 9-1/2", 11-7/8", 14"
 Web Thickness: 3/8"
 Flange Material: Solid Sawn
 Flange Depth: 1-1/2"
 Lengths: Up to 64' in 2' increments

LPI 20Plus

Width: 2-1/2"
 Depths: 9-1/2", 11-7/8", 14", 16"
 Web Thickness: 3/8"
 Flange Material: Solid Sawn
 Flange Depth: 1-1/2"
 Lengths: Up to 64' in 2' increments

LPI 32Plus

Width: 2-1/2"
 Depths: 9-1/2", 11-7/8", 14", 16"
 Web Thickness: 3/8"
 Flange Material: Solid Sawn
 Flange Depth: 1-1/2"
 Lengths: Up to 64' in 2' increments

LPI 36

Width: 2-1/4"
 Depths: 11-7/8", 14", 16"
 Web Thickness: 3/8"
 Flange Material: LVL
 Flange Depth: 1-1/2"
 Lengths: Up to 64' in 2' increments

LPI 42Plus

Width: 3-1/2"
 Depths: 9-1/2", 11-7/8", 14", 16"
 Web Thickness: 3/8"
 Flange Material: Solid Sawn
 Flange Depth: 1-1/2"
 Lengths: Up to 64' in 2' increments

LPI 52Plus

Width: 3-1/2"
 Depths: 11-7/8", 14", 16"
 Web Thickness: 7/16"
 Flange Material: Solid Sawn
 Flange Depth: 1-1/2"
 Lengths: Up to 64' in 2' increments

LPI 56

Width: 3-1/2"
 Depths: 11-7/8", 14", 16"
 Web Thickness: 7/16"
 Flange Material: LVL
 Flange Depth: 1-1/2"
 Lengths: Up to 64' in 2' increments

CODE EVALUATION

CMMC evaluation reports can be obtained at www.nrc-cnrc.gc.ca.
 CMMC 12412-R
 APA PR-L238C



For more information on the full line of LP® SolidStart® Engineered Wood Products or the nearest distributor, visit our web site at LPCorp.com.

Phone: 1-888-820-0325
 E-mail: customer.support@LPCorp.com.

LP SolidStart Engineered Wood Products are manufactured at different locations in the United States and Canada. Please verify availability with the LP SolidStart Engineered Wood Products distributor in your area before specifying these products.



© 2016 Louisiana-Pacific Corporation. All rights reserved. APA and APA Rated are registered trademarks of APA – The Engineered Wood Association, SIMPSON Strong-Tie® is a registered trademark of Simpson Strong-Tie Company, Inc., USP® is a registered trademark of MiTek Holdings, Inc., SFI and the associated logo are trademarks of Sustainable Forestry Initiative, Inc., PEFC and the associated logo are trademarks of Programme for the Endorsement of Forest Certification, LP® and SolidStart® are registered trademarks of Louisiana-Pacific Corporation. Printed in USA. Specifications (details) subject to change without notice.
 NOTE: Louisiana-Pacific Corporation periodically updates and revises its product information. To verify that this version is current, contact the nearest sales office, visit LPCorp.com, or call 1-888-820-0325.